

YAMAHA

YFZ350J/K

**SUPPLEMENTARY
SERVICE MANUAL**

FOREWORD

This Supplementary Service Manual has been prepared to introduce new service and data for the YFZ350J/K. For complete information on service procedures, it is necessary to use this Supplementary Service Manual together with following manual:

YFZ350T '86 SERVICE MANUAL: 2GU-10
YFZ350A '89 SUPPLEMENTARY SERVICE MANUAL: 3GG-10
YFZ350B '90 SUPPLEMENTARY SERVICE MANUAL: 3GG-11

YFZ350J/K
SUPPLEMENTARY SERVICE MANUAL
©1997 by Yamaha Motor Corporation, U.S.A.
1st Edition, April 1997 All rights reserved.
Any reprinting or unauthorized use without
the written permission of
Yamaha Motor Corporation, U.S.A.
is expressly prohibited.
Printed in U.S.A.
LIT-11616-10-95

NOTICE

This manual was produced by the Yamaha Motor Company primarily for use by Yamaha dealers and their qualified mechanics. It is not possible to include all the knowledge of a mechanic in one manual, so it is assumed that anyone who uses this book to perform maintenance and repairs on Yamaha machines has a basic understanding of the mechanical ideas and the procedures of machine repair. Repairs attempted by anyone without this knowledge are likely to render the machine unsafe and unfit for use.

Yamaha Motor Company, Ltd. is continually striving to improve all its models. Modifications and significant changes in specifications or procedures will be forwarded to all authorized Yamaha dealers and will appear in future editions of this manual where applicable.

NOTE:

Designs and specifications are subject to change without notice.

IMPORTANT INFORMATION

Particularly important information is distinguished in this manual by the following notations.



The Safety Alert Symbol means ATTENTION! BECOME ALERT! YOUR SAFETY IS INVOLVED!

WARNING

Failure to follow WARNING instructions could result in severe injury or death to the machine operator, a bystander or a person inspecting or repairing the machine.

CAUTION:

A CAUTION indicates special precautions that must be taken to avoid damage to the machine.

NOTE:

A NOTE provides key information to make procedures easier or clearer.

HOW TO USE THIS MANUAL

CONSTRUCTION OF THIS MANUAL

This manual consists of chapters for the main categories of subjects. (See "Illustrated symbols")

- 1st title ① : This is a chapter with its symbol on the upper right of each page.
- 2nd title ② : This title appears on the upper of each page on the left of the chapter symbol. (For the chapter "Periodic inspection and adjustment "the 3rd title appears.)
- 3rd title ③ : This is a final title.

MANUAL FORMAT

All of the procedures in this manual are organized in a sequential, step-by-step format. The information has been compiled to provide the mechanic with an easy to read, handy reference that contains comprehensive explanations of all disassembly , repair, assembly and inspections.

A set of particularly important procedure (④) is placed between a line of asterisks (*); with each procedure preceded by (●).









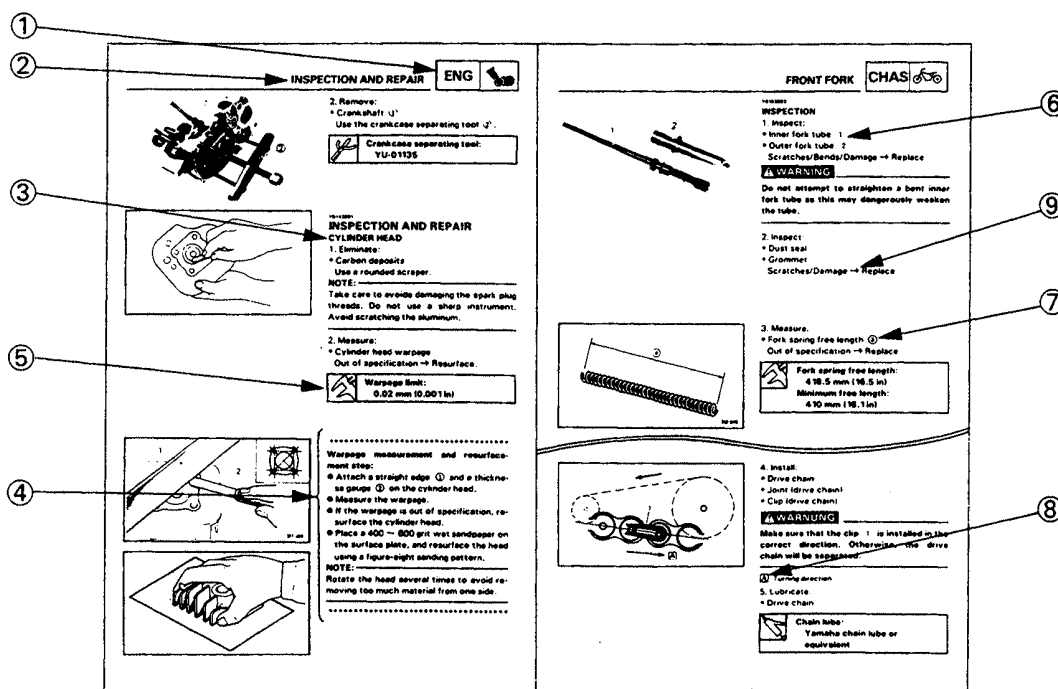













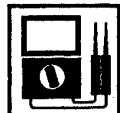

IMPORTANT FEATURES

- Data and a special tool are framed in a box preceded by a relevant symbol (⑤).
- An encircled numeral (⑥) indicates a part name, and an encircled alphabetical letter data or an alignment mark (⑦), the others being indicated by an alphabetical letter in a box (⑧).
- A condition of a faulty component will precede an arrow symbol and course of action required the symbol (⑨).

EXPLODED DIAGRAM

Each chapter provides exploded diagrams before each disassembly section for ease in identifying correct disassembly and assembly procedures.



① GEN INFO 	② SPEC 		
③ INSP ADJ 	④ ENG 		
⑤ COOL 	⑥ CARB 		
⑦ DRIV 	⑧ CHAS 		
⑨ ELEC 	⑩ TRBL SHTG 		
⑪ 	⑫ 		
⑬ 	⑭ 		
⑮ 	⑯ 		
⑰ 	⑱ 	⑲ 	⑳ 
⑳ 	㉑ 	㉒ 	
㉓ 	㉔ New		

EB003000

ILLUSTRATED SYMBOLS

Illustrated symbols ① to ⑨ are designed as thumb tabs to indicate the chapter's number and content.

- ① General information
- ② Specifications
- ③ Periodic inspection and adjustment
- ④ Engine
- ⑤ Cooling system
- ⑥ Carburetion
- ⑦ Drive train
- ⑧ Chassis
- ⑨ Electrical
- ⑩ Troubleshooting

Illustrated symbols ⑪ to ⑰ are used to identify the specifications appearing in the text.

- ⑪ Filling fluid
- ⑫ Lubricant
- ⑬ Special tool
- ⑭ Tightening
- ⑮ Wear limit, clearance
- ⑯ Engine speed
- ⑰ Ω , V, A

Illustrated symbols ⑱ to ㉓ in the exploded diagrams indicate the types of lubricants and lubrication points.

- ⑱ Apply engine oil
- ⑲ Apply gear oil
- ⑳ Apply molybdenum disulfide oil
- ㉑ Apply wheel bearing grease
- ㉒ Apply lightweight lithium-soap base grease
- ㉓ Apply molybdenum disulfide grease

Illustrated symbols ㉔ to ㉕ in the exploded diagrams indicate the where to apply locking agent ㉔ and when to install new parts ㉕.

- ㉔ Apply locking agent (LOCTITE®)
- ㉕ Use new one

CONTENTS

GENERAL INFORMATION	1
MACHINE IDENTIFICATION	1
VEHICLE IDENTIFICATION NUMBER	1
MODEL LABEL	1
SPECIFICATIONS	2
GENERAL SPECIFICATIONS	2
MAINTENANCE SPECIFICATIONS	2
ENGINE.....	2
ELECTRICAL.....	2
CABLE ROUTING	3
PERIODEC INSPECTIONS AND ADJUSTMENTS	7
INTRODUCTION	7
PERIODEC MEINTENANCE/LUBRICATION INTERVALS	7
ELECTRICAL	9
IGNITION SYSTEM	9
CIRCUIT DIAGRAM	9
ENGINE REVOLUTION LIMITER SYSTEM	10
TROUBLESHOOTING	11
YFZ350J/K WIRING DIAGRAM	

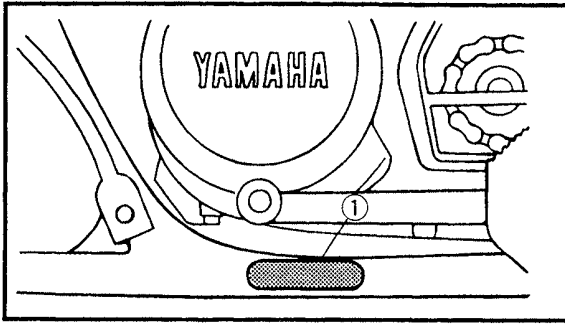

EB100000

GENERAL INFORMATION
MACHINE IDENTIFICATION

VEHICLE IDENTIFICATION NUMBER

The vehicle identification number ① is stamped into the left side of the down tube.

NOTE: _____

The vehicle identification number is used to identify your machine.

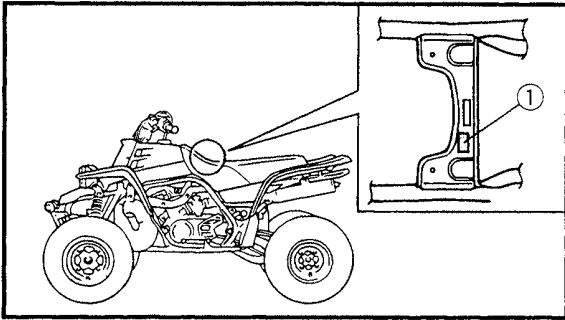

MODEL LABEL

The model label ① is affixed to the frame under the seat. Record the information on this label in the space provided.

This information will be needed to order spare parts.

GENERAL SPECIFICATIONS



SPECIFICATIONS

GENERAL SPECIFICATIONS

Model	YFZ350J/K
Model code number:	YFZ350J('97): 3GGS (US) 3GGT (F) YFZ350K('98): 3GGW(US) 3GGV(CDN) 3GGX(F)
Basic weight: With oil and full fuel tank	187 kg (412 lb)
Spark plug: Type Manufacturer Gap	B8ES/W24ES NGK/DENSO 0.7~0.8 mm (0.028~0.031 in)

MAINTENANCE SPECIFICATIONS

ENGINE

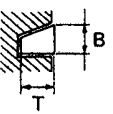
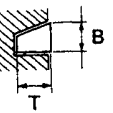
Model	YFZ350J/K
Piston ring: Top ring: Type Dimensions (B x T)  End gap (Installed) <Limit> Side clearance (Installed) <Limit>	Keystone 1.2 x 2.6 mm (0.047~0.102 in) 0.6~0.8 mm (0.024~0.031 in) 1.0 mm (0.39 in) 0.02~0.06 mm (0.0008~0.0024 in) 0.12 mm (0.0047 in)
2nd ring: Type Dimensions (B x T)  End gap (Installed) <Limit> Side clearance (Installed) <Limit>	Keystone 1.5 x 2.5 mm (0.059~0.098 in) 0.6~0.8 mm (0.024~0.031 in) 1.0 mm (0.39 in) 0.02~0.06 mm (0.0008~0.0024 in) 0.12 mm (0.0047 in)
Carburetor: Float height (F.H.)	20.5~21.5 mm (0.807~0.845 in)

ELECTRICAL

Model	YFZ350J/K
C.D.I.: Magneto model/Manufacturer C.D.I. unit model/Manufacturer	VCE33/DENSO 3GG-10/DENSO
Ignition coil: Model/Manufacturer	JO146/DENSO
Flywheel magneto: Model/Manufacturer	VCE33/DENSO



CABLE ROUTING

- ① Throttle switch lead
- ② Throttle cable
- ③ Fuel tank breather hose
- ④ Band
- ⑤ Parking brake switch
- ⑥ Parking brake cable
- ⑦ Clutch cable
- ⑧ Front brake hose
- ⑨ Clamp
- ⑩ Breather hose

- A Pass the cable in front of the front brake hose.
- B Pass the cables behind the front brake hose.
- C Pass the hose through the handle protector hole
- D Pass the hose and lead in front of the cable guide. Pass the handbar switch lead and parking switch lead behind the cable guide.
- E Clamp the hoses.
- F Pass the hoses through the hose guide.

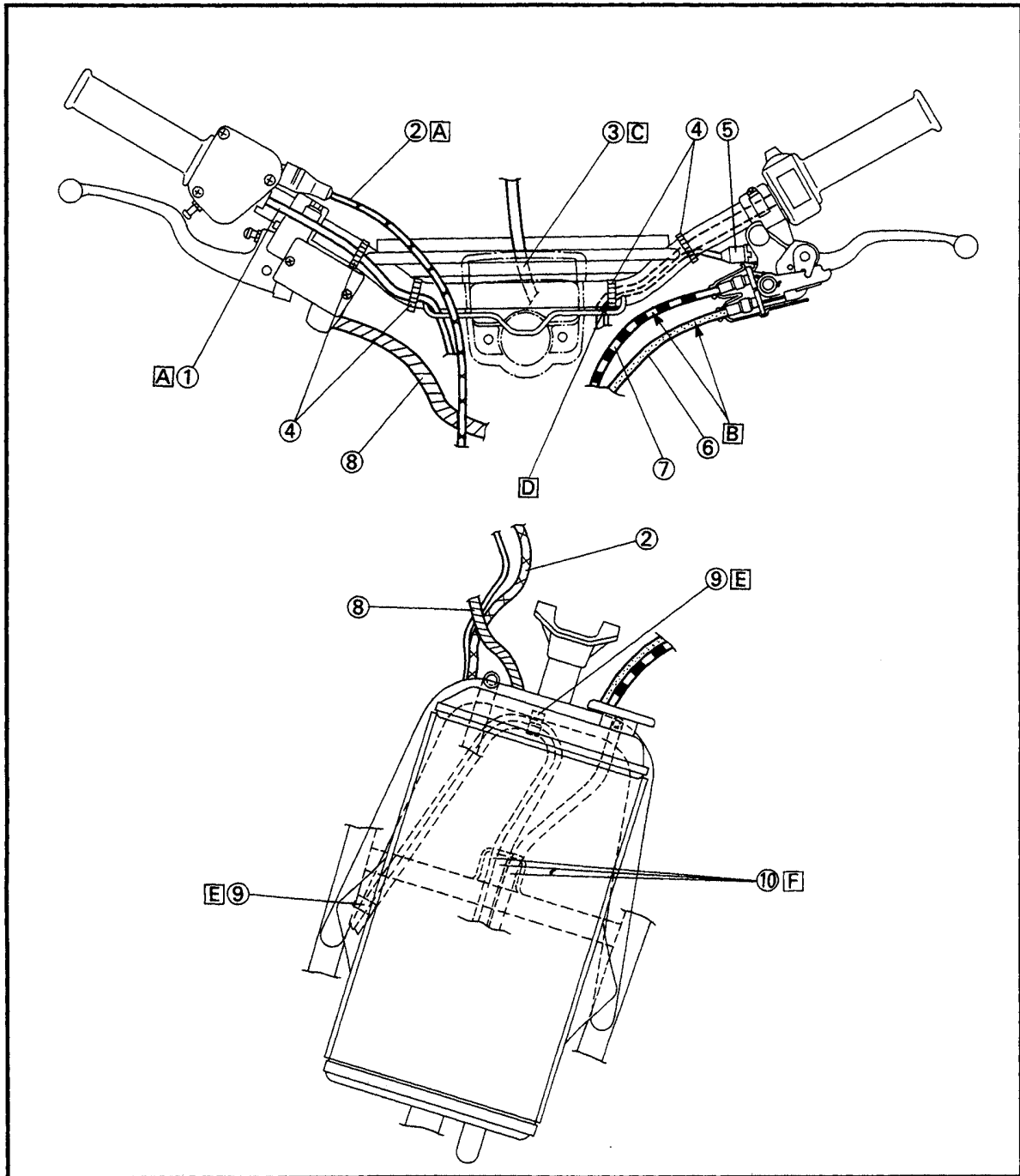

CABLE ROUTING

SPEC



- ① Main switch
- ② Wireharness
- ③ Fuel hose
- ④ Crankcase breather hose
- ⑤ Carburetor over flow hose
- ⑥ Radiator hose
- ⑦ Throttle switch lead
- ⑧ Engine stop switch lead
- ⑨ Handle switch lead

- Ⓐ Pass the wireharness into the guide. Align the marking tape at the guide.
- Ⓑ Pass the hose into the guide.
- Ⓒ Do not pass the hose into the guide. Pass the hose behind the brake hose.

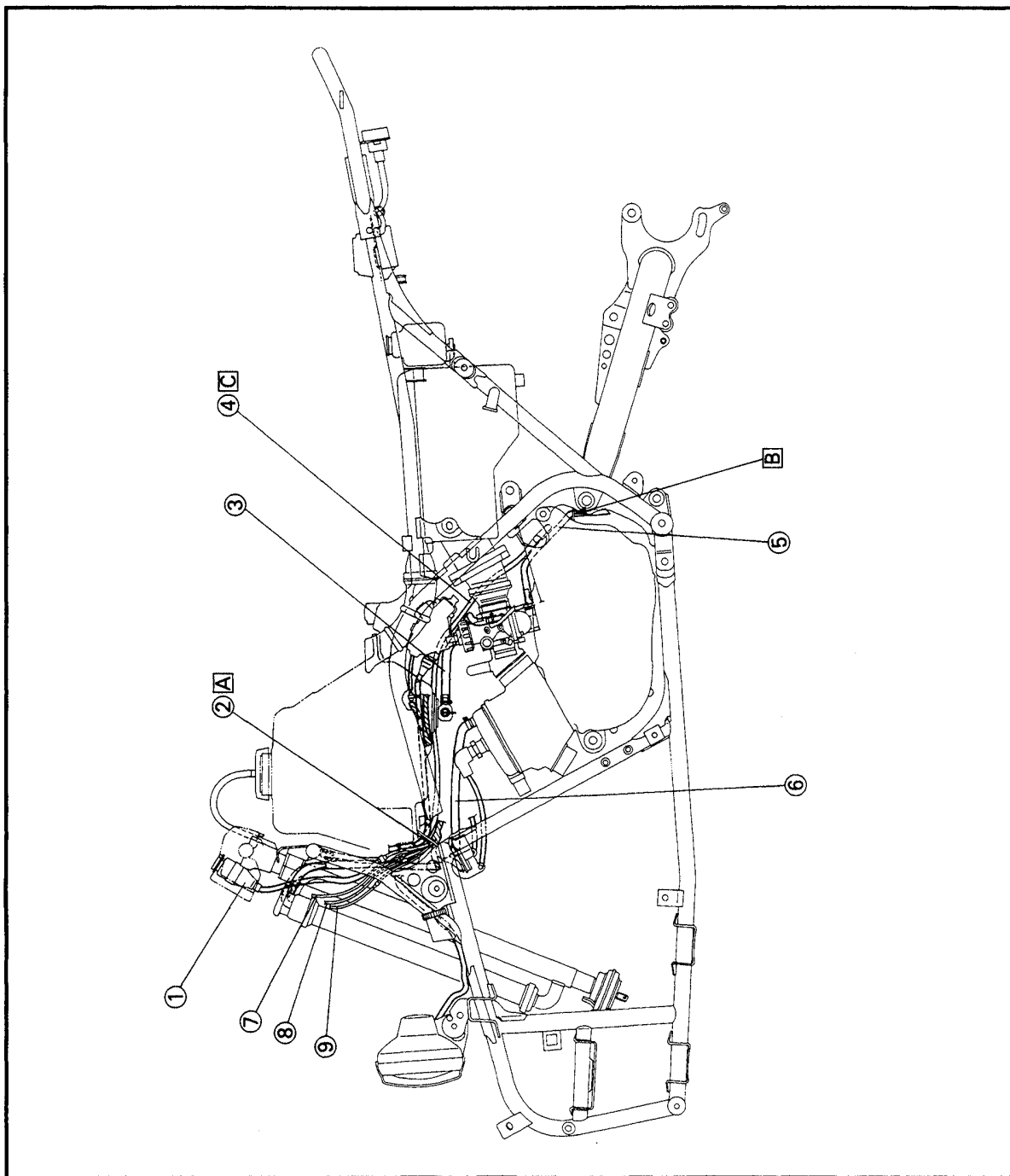

- ① Carburetor switch lead
- ② Throttle cable
- ③ Band
- ④ Clutch cable
- ⑤ Parking brake cable
- ⑥ Breather hose
- ⑦ Cable guide
- ⑧ C.D.I. magneto lead
- ⑨ Wireharness
- ⑩ Clamp

- A Pass the wireharness and hoses through the guide on the air cleaner.
- B Pass the lead above the hoses and cables.
- C Pass the cable through the guide.
- D Route the hose behind the clutch and parking cable. Pass the hose between both carburetor joint.
- E Route the cable behind the rear brake hose.
- F Pass the hoses inside the wireharness.

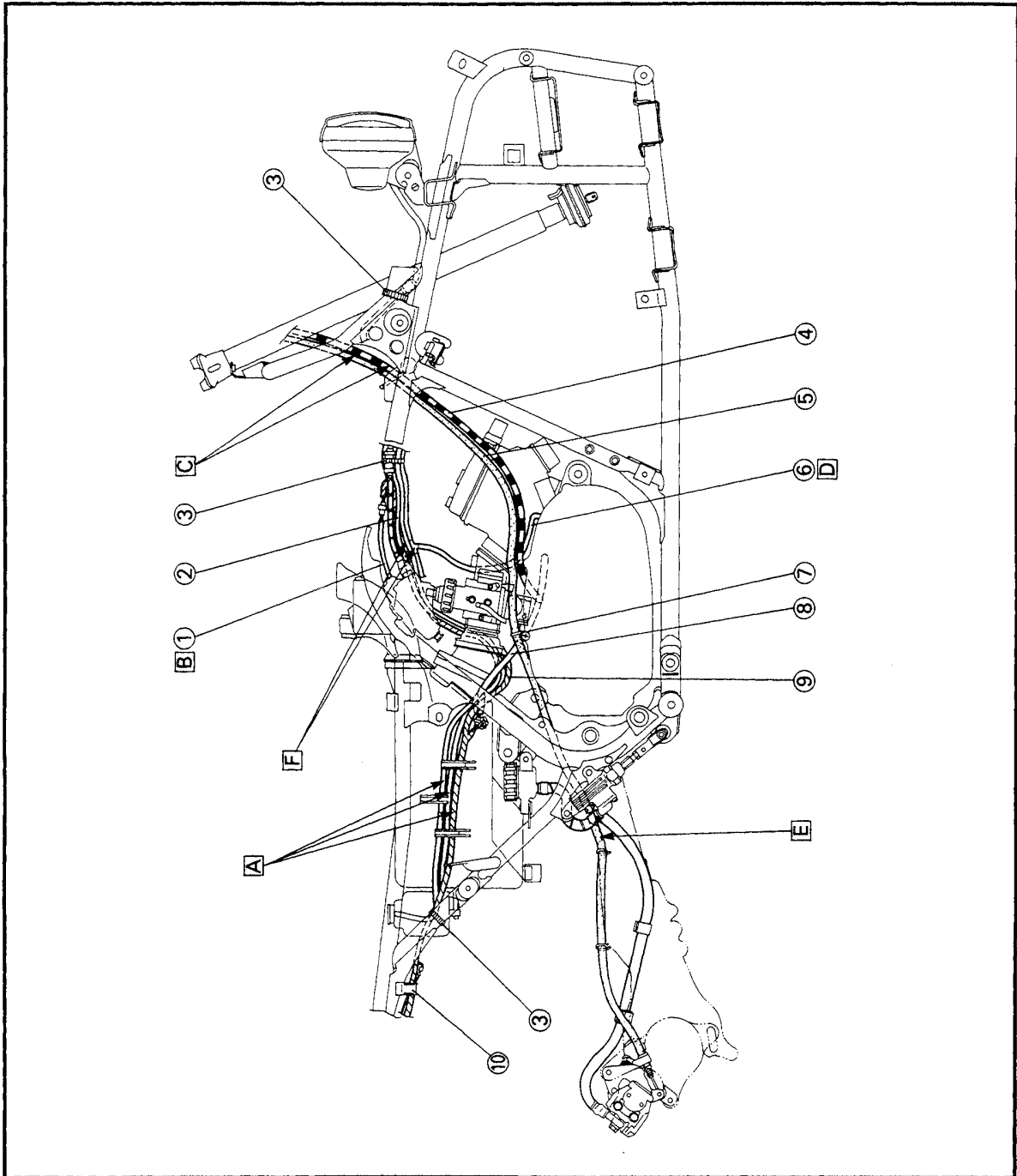

- ① Headlight
- ② Ignition coil
- ③ Wireharness
- ④ Reservoir tank
- ⑤ Voltage regulator
- ⑥ Body earth
- ⑦ Band
- ⑧ Clamp
- ⑨ C.D.I. unit
- ⑩ Carburetor switch lead
- ⑪ T.O.R.S. control unit

- A** Ignition coil lead (Orange)
- B** Ignition coil lead (Black)

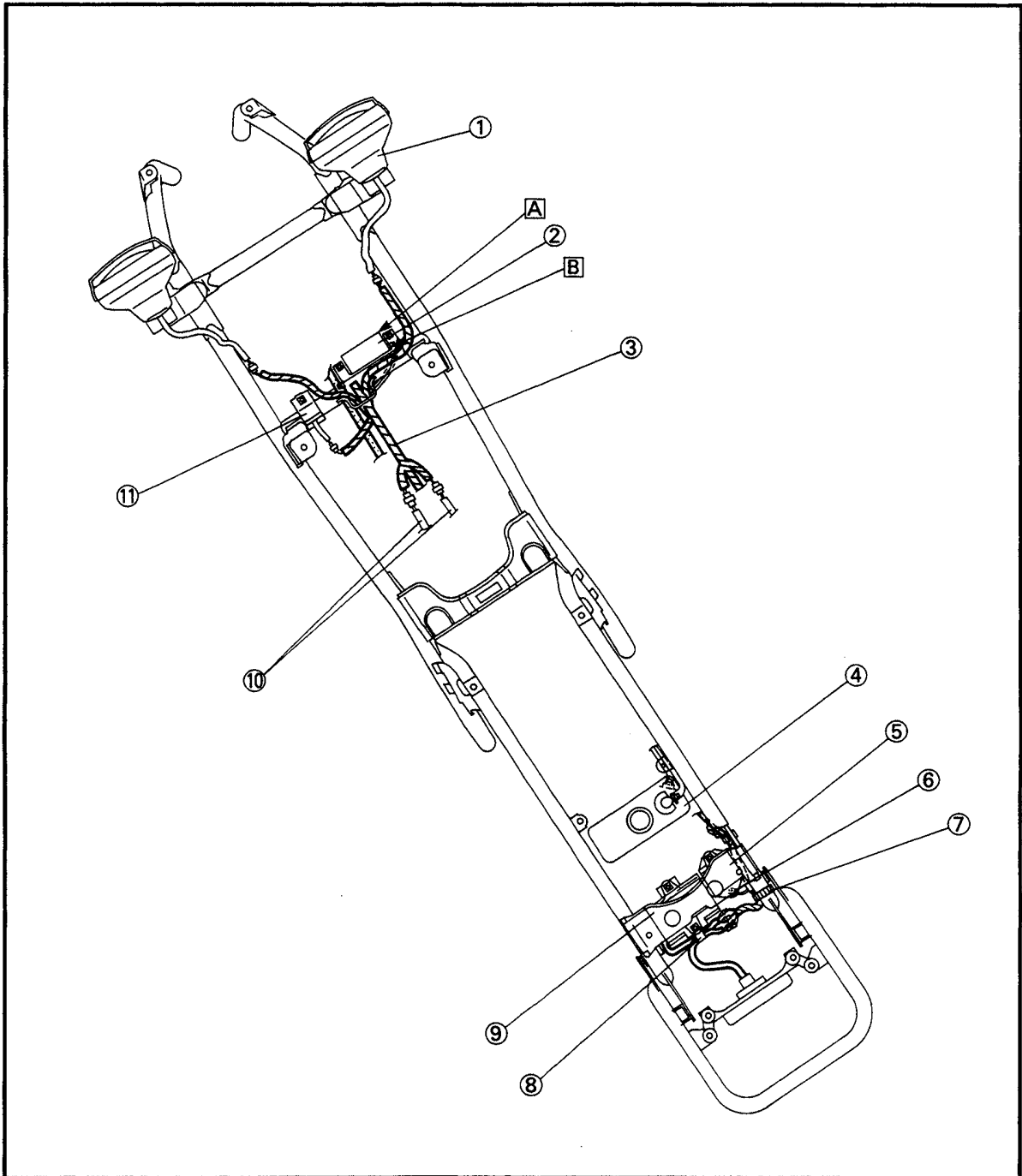

INTRODUCTION/ PERIODIC MAINTENANCE/LUBRICATION INTERVALS



EB300000

PERIODIC INSPECTIONS AND ADJUSTMENTS

INTRODUCTION

This chapter includes all information necessary to perform recommended inspections and adjustments. These preventive maintenance procedures, if followed, will ensure more reliable vehicle operation and a longer service life. The need for costly overhaul work will be greatly reduced. This information applies to vehicles already in service as well as to new vehicles that are being prepared for sale. All service technicians should be familiar with this entire chapter.

YF301000

PERIODIC MAINTENANCE/LUBRICATION INTERVALS

ITEM	ROUTINE	INITIAL			EVERY	
		1 month	3 months	6 months	6 months	1 year
Transmission	Replace oil	○		○	○	○
Cooling system	Check coolant leakage. Repair if necessary Replace coolant every 24 months.	○	○	○	○	○
Spark plug	Check condition. Clean or replace if necessary.	○	○	○	○	○
Air filter	Clean. Replace if necessary.	Every 20-40 hours. (More often in wet or dusty areas)				
Carburetor*	Check idle speed/starter operation. Adjust if necessary.		○	○	○	○
Fuel line*	Check fuel hose for cracks or damage. Replace if necessary.			○	○	○
Throttle operation	Inspect and adjust free play, if necessary.	○	○	○	○	○
Front and rear brake operation*	Check operation/fluid leakage/See NOTE. Correct if necessary.	○	○	○	○	○
Front and rear brake pads*	Check pads wear. Replace if necessary.			○	○	○
Clutch*	Inspect free play and operation. Replace if necessary.	○		○	○	○
Drive chain	Check chain slack/aliment. Adjust if necessary. Clean and lube. Replace if necessary.	○		○	○	○
Drive chain guard and rollers*	Check wear and replace if necessary.			○	○	○
Steering system*	Inspect free play, clean and lubricate.	○	○	○	○	○
Front and rear suspension*	Inspect and lubricate.**	○	○	○	○	○
Tires, wheels	Inspect air pressure, wheel runout, and tire wear. Inspect bearings.* Replace bearings if necessary.*	○	○	○	○	○
Throttle, control cable	Check routing and connection. Lubricate.	○	○	○	○	○
Outside nuts and bolts	Retighten.	○	○	○	○	○
Frame	Clean and inspect.		○	○	○	○
Lighting equipment	Inspect.	○	○	○	○	○

*: It is recommended that these items be serviced by a Yamaha dealer.

***: Lithium soap base grease.

PERIODIC MAINTENANCE/LUBRICATION INTERVALS



NOTE: _____

Brake fluid replacement:

1. When disassembling the master cylinder or caliper cylinder, replace the brake fluid. Normally check the brake fluid level and add the fluid as required.
 2. On the inner parts of the master cylinder and caliper cylinder, replace the oil seals every two years.
 3. Replace the brake hoses every four years, or if cracked or damaged.
-

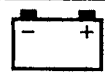

ELECTRICAL

IGNITION SYSTEM
CIRCUIT DIAGRAM

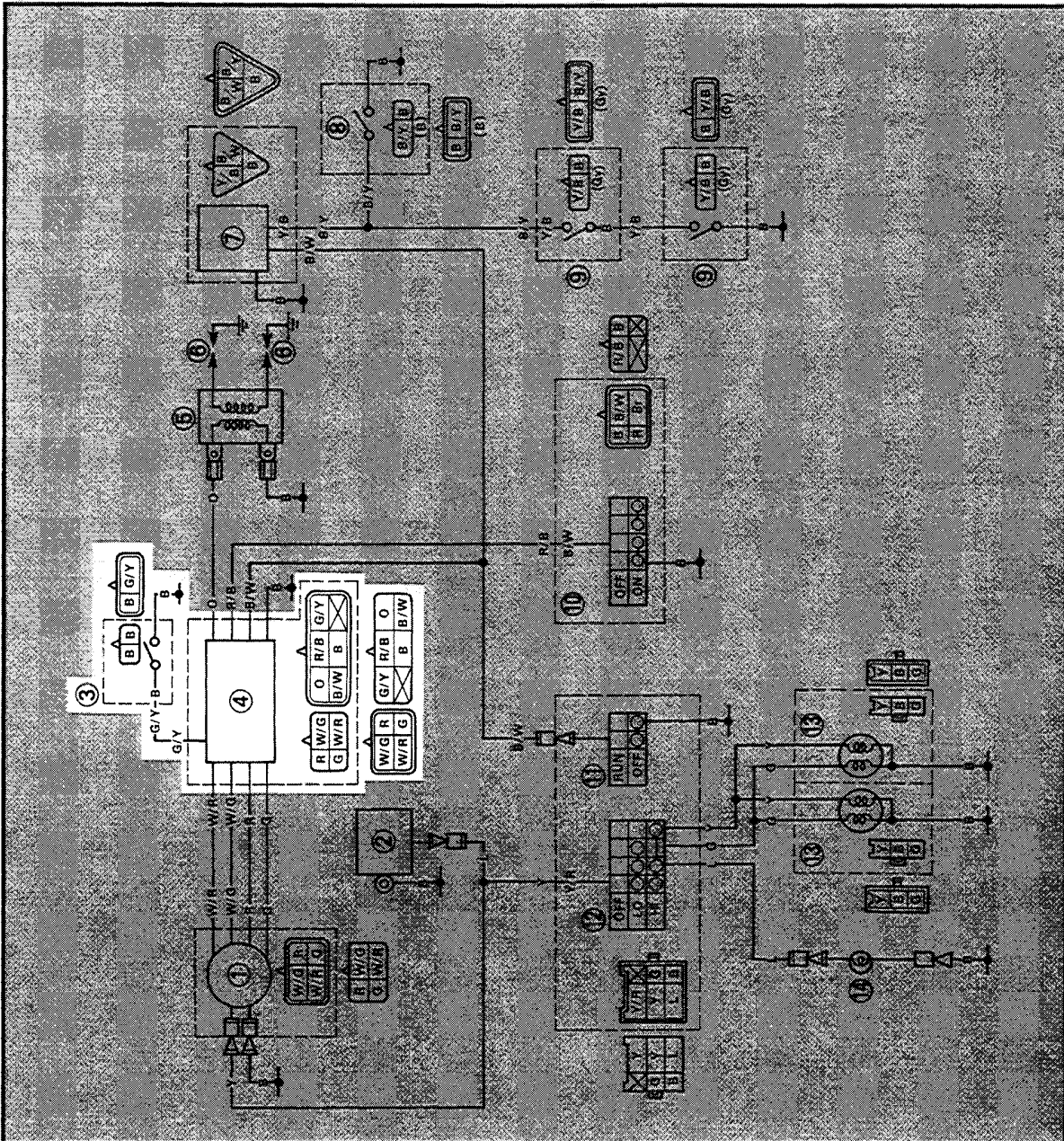

- ③ Parking switch
- ④ C.D.I. unit

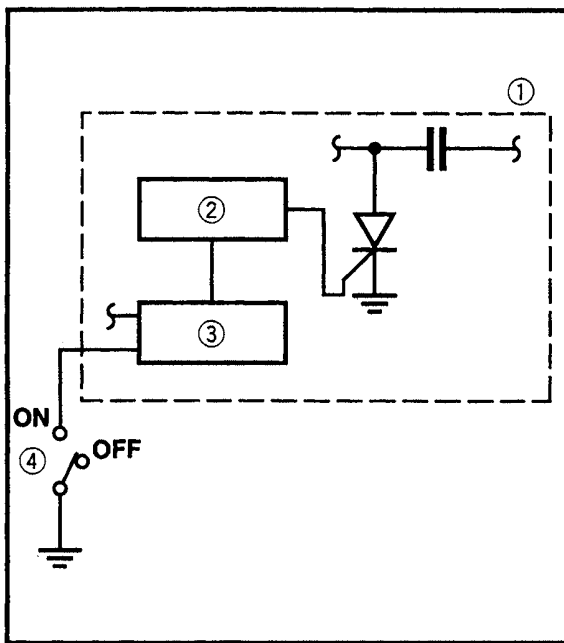

ENGINE REVOLUTION LIMITER SYSTEM

when the parking brake is applied, the engine revolution limiter system becomes activated, thereby letting the rider know that the parking brake is on.

System

A switch is newly provided on the parking brake lever on the left of the handlebar to sense the parking brake condition.

The ignition unit which receives a sensed signal becomes activated as follows according to the parking brake condition.

- Parking brake is released.
(switch OFF) → Ignition occurs normally.
- Parking brake is applied.
(switch ON) → Misfire occurs at 2,300 r/min.
(engine will not rev up beyond 2,300 r/min.)

- ① C.D.I. unit
- ② Ignition timing control circuit
- ③ Engine revolution limiter control circuit
- ④ Parking switch



TROUBLESHOOTING

**IF THE ENGINE REVOLUTION LIMITER SYSTEM FAILS TO OPERATE.
(WHEN THE PARKING BRAKE IS APPLIED, ENGINE WILL REV OVER THE 2,300 r/min.)**

Procedure

Check:

- | | |
|---------------------------|--------------------------|
| 1. Engine misfiring range | 3. Wiring connection |
| 2. Parking switch | (entire ignition system) |

NOTE:

- Remove the following parts before troubleshooting.

1) Seat	3) Rear fender
2) Front fender	
- Use the special tools specified in the trouble shooting section.

Inductive Tachometer
YU-08036

Engine Tachometer
90890-03113

Pocket tester:
YM-03112/90890-03112

1. Engine misfiring range

- Attach the Inductive Tachometer or engine tachometer to the spark plug lead.
- Start the engine, then, shift the gear in neutral position and set the parking brake.
- Check the misfiring nearly 2,300 r/min.

Misfiring engine speed:
nearly 2,300 r/min

MEET SPECIFICATION

Engine revolution limiter system is good.

2. Parking switch

- Disconnect the parking switch coupler from the wireharness.
- Connect the pocket tester ($\Omega \times 1$) to the parking switch coupler.
- Check the switch for continuity.

Parking brake	Good condition	Bad condition		
Apply	○ (Continuity)	×	○	×
Release	×	×	○	○

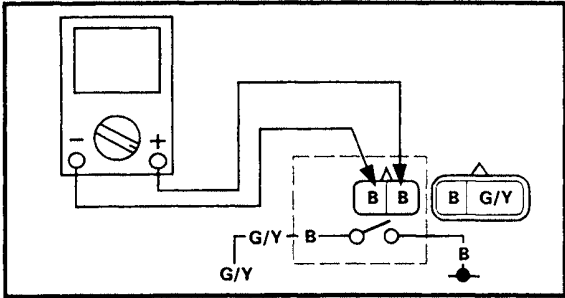

BAD CONDITION

Replace the parking switch.

OUT OF SPECIFICATION

GOOD CONDITION

*

