



CHAPTER 3 ENGINE OVERHAUL

ENGINE REMOVAL	3-1
PREPARATION FOR REMOVAL	3-1
FRONT FENDER	3-2
REAR FENDER	3-2
FUEL TANK	3-2
EXHAUST PIPE AND SILENCER	3-3
CARBURETOR	3-3
CHANGE PEDAL	3-4
CDI MAGNETO	3-4
DRIVE CHAIN	3-5
TENSION ROD	3-5
CABLES	3-6
ENGINE REMOVAL	3-6
 DISASSEMBLY	 3-8
CYLINDER HEAD	3-8
REED VALVE ASSEMBLY	3-8
RADIATOR HOSE	3-8
CYLINDER	3-9
PISTON PIN AND PISTON	3-9
KICK CRANK	3-9
CRANKCASE COVER (RIGHT)	3-10
CLUTCH AND PRIMARY DRIVE GEAR	3-10
KICK AXLE	3-11
CHANGE SHAFT	3-12
STATOR ASSEMBLY	3-12
CAM STOPPER PLATE	3-12
BEARING STOPPER PLATE	3-12
CRANKCASE	3-13
PUSH LEVER	3-13
TRANSMISSION	3-13
SHIFTER	3-14
CRANKSHAFT	3-14

INSPECTION AND REPAIR	3-15
CYLINDER HEAD	3-15
CYLINDER	3-15
PISTON, PISTON RING AND PISTON PIN	3-16
JOINT PIPE	3-19
CLUTCH	3-19
PRIMARY DRIVE GEAR	3-21
KICK STARTER	3-21
SHIFTER	3-21
TRANSMISSION	3-22
CRANKSHAFT	3-23
BEARINGS AND OIL SEAL	3-24
CIRCLIPS AND WASHERS	3-24
CRANKCASE	3-24
 ENGINE ASSEMBLY AND ADJUSTMENT	 3-25
CRANKSHAFT	3-25
SHIFTER	3-27
TRANSMISSION	3-29
CRANKCASE	3-31
CHANGE SHAFT	3-32
KICK AXLE	3-33
CLUTCH AND PRIMARY DRIVE GEAR	3-34
CRANKCASE COVER (RIGHT)	3-38
KICK CRANK	3-38
PISTON PIN AND PISTON	3-38
CYLINDER	3-39
RADIATOR HOSE	3-40
REED VALVE ASSEMBLY	3-40
CYLINDER HEAD	3-40
CDI MAGNETO	3-42
REMOUNTING ENGINE	3-42



ENGINE OVERHAUL

ENGINE REMOVAL

NOTE: _____

It is not necessary to remove the engine in order to remove the cylinder and/or the flywheel magneto assembly.

PREPARATION FOR REMOVAL

1. Remove all dirt, mud, dust and foreign material before removal and disassembly.
2. Use proper tools and cleaning equipment. Refer to "CHAPTER 1. GENERAL INFORMATION-SPECIAL TOOLS" section.

NOTE: _____

When disassembling the engine, keep mated parts together. This includes gears, cylinder, piston and other parts that have been "mated" through normal wear. Mated parts must be reused as an assembly or replaced.

3. During engine disassembly, clean all parts and place them in trays in the order of disassembly. This will speed up assembly time and help assure that all parts are correctly reinstalled in the engine.
4. Start the engine and allow it to warm up.
5. Drain the engine oil completely. Refer to "CHAPTER 2. PERIODIC INSPECTIONS AND ADJUSTMENTS — ENGINE OIL REPLACEMENT" section.
6. Drain the coolant completely. Refer to "CHAPTER 2. COOLANT REPLACEMENT" section.

ENGINE REMOVAL

ENG

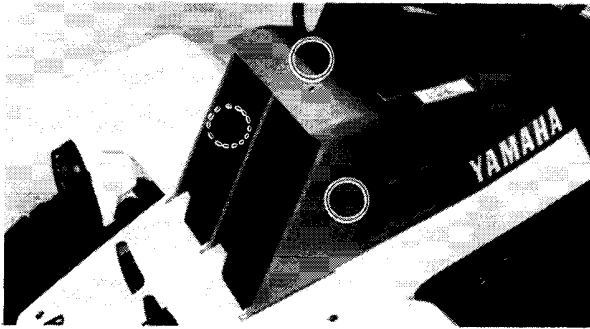

FRONT FENDER

1. Remove:

- Seat
- Radiator cover

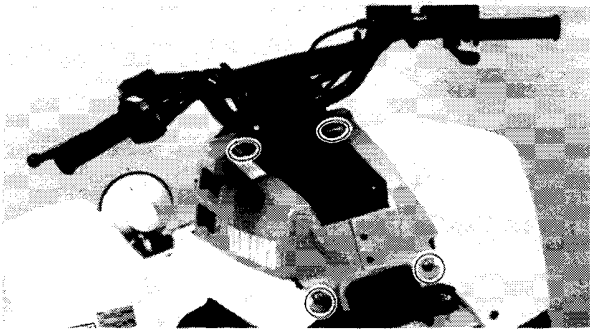

2. Remove:

- Fuel tank cover

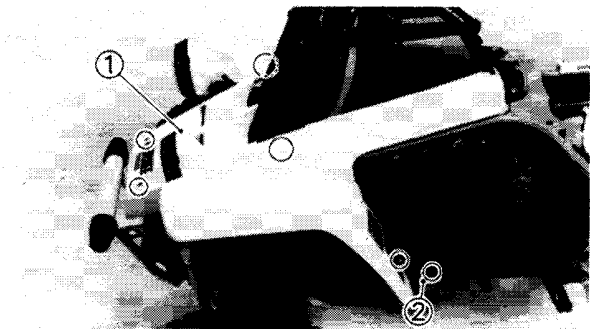

3. Remove:

- Front fender ①
- Front fender stays ②

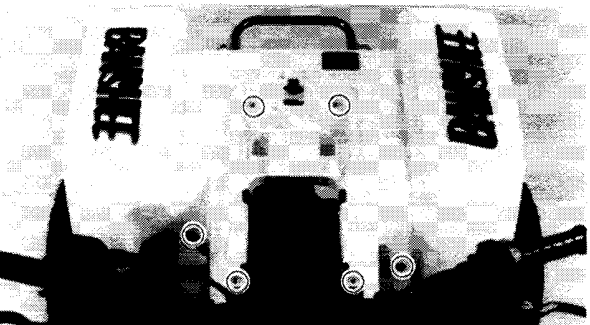

REAR FENDER

1. Remove:

- Rear fender

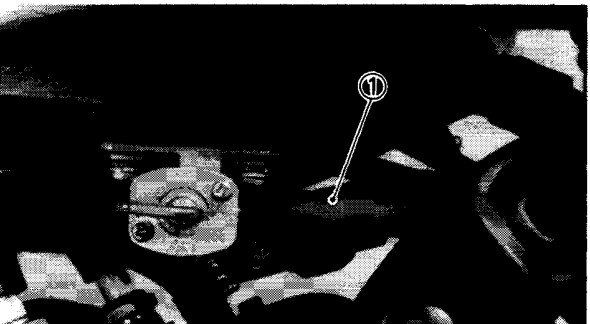

FUEL TANK

1. Turn the fuel cock to the "OFF" position.

2. Disconnect:

- Fuel hose ①

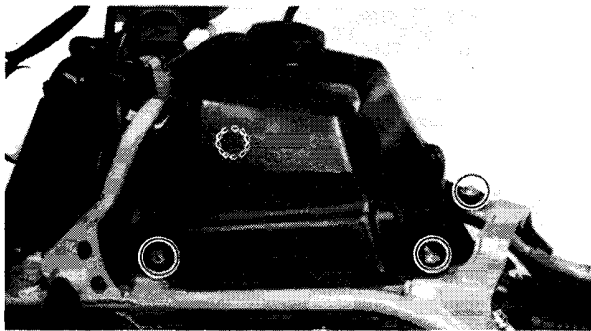

3. Remove:
•Fuel tank

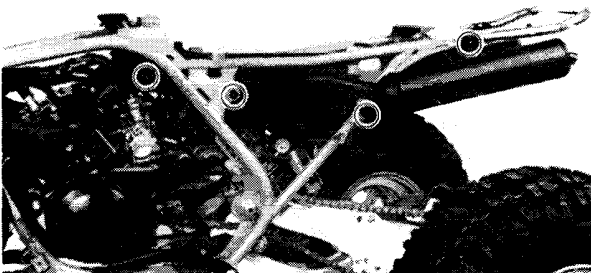

EXHAUST PIPE AND SILENCER

1. Remove:
•Silencers

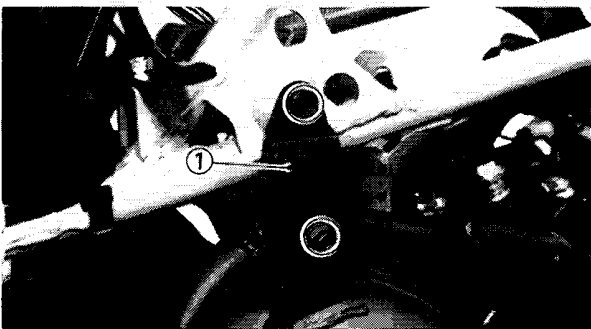

2. Remove:
•Exhaust pipe stays ①

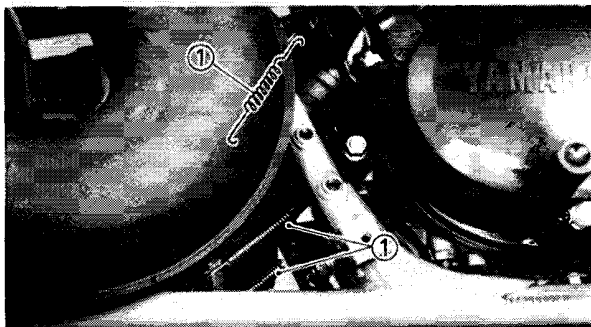

3. Remove:
•Springs ①
Use the general spring remover.
•Exhaust pipes

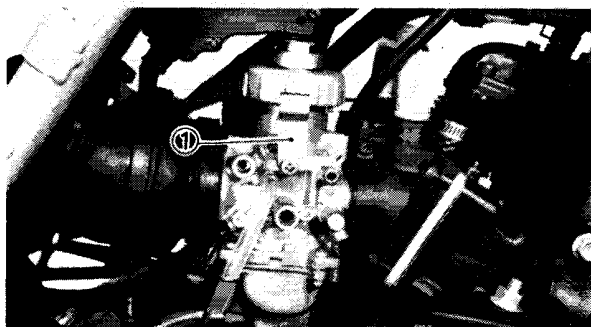

CARBURETOR

1. Remove:
•Stopper plates ①

ENGINE REMOVAL

ENG

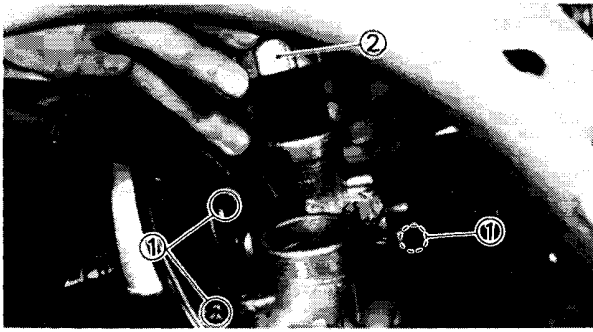

2. Loosen:
 - Carburetor joint holding screws ①
3. Remove:
 - Carburetor top ② together with throttle valve

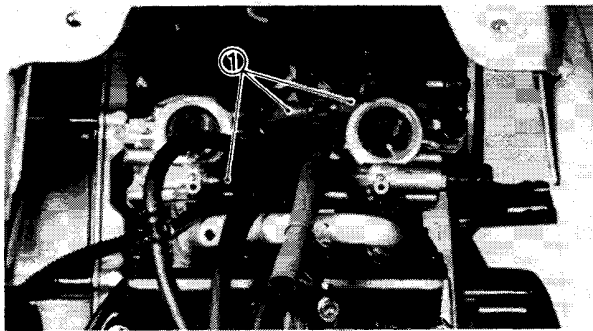

4. Remove:
 - Hoses ①
 - Carburetors

NOTE:

Cover the carburetor with a clean rag to prevent dirt or foreign matter into the carburetor.

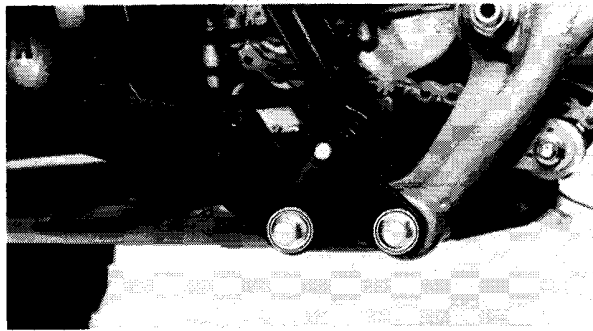

CHANGE PEDAL

1. Remove:
 - Footrests

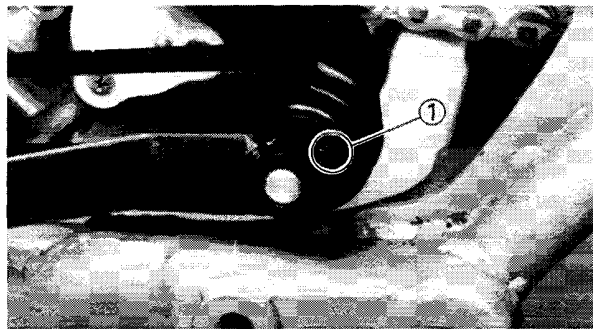

2. Remove:
 - Bolt ①
 - Change pedal

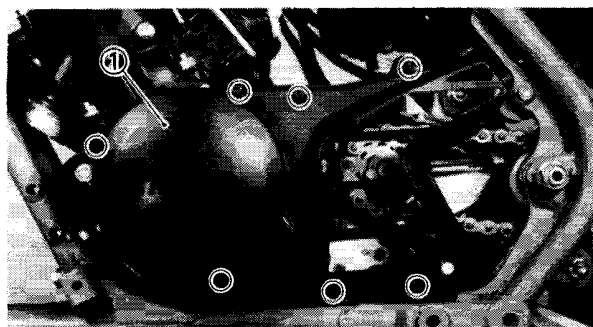

CDI MAGNETO

1. Remove:
 - Crankcase cover (Left) ①

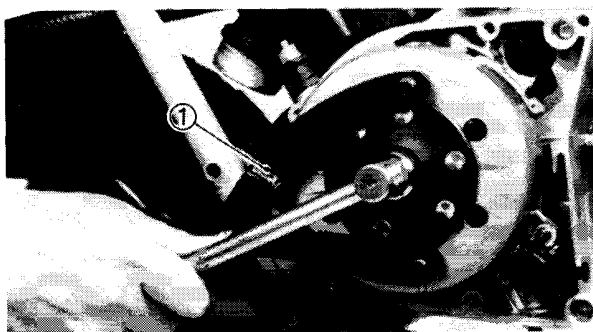

2. Remove:
 - Nut (Magneto)
 - Use the Rotor Holding Tool ① (YU-01235) to lock the magneto.

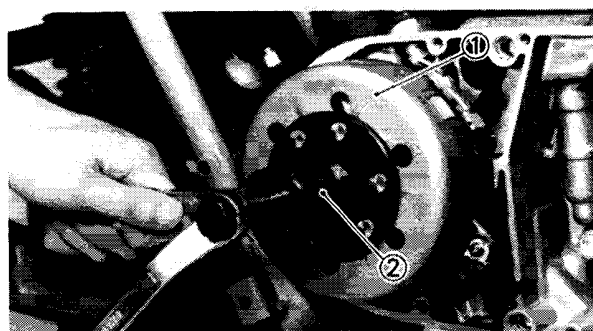

3. Remove:
 - CDI magneto ①
 - Use the Rotor Puller ② (YM-01189).
 - Woodruff key

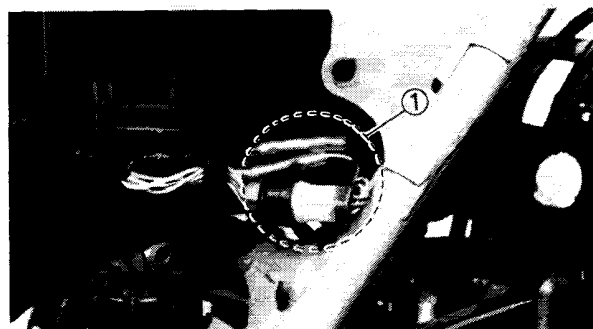

4. Disconnect:
 - Magneto leads ①

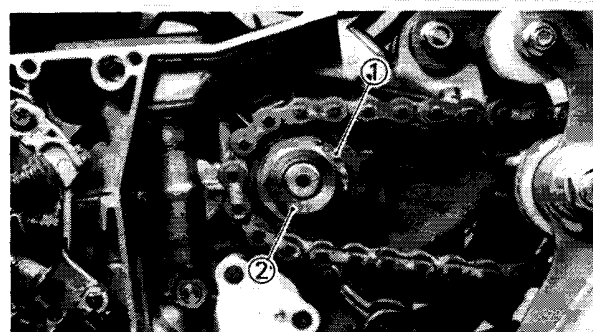

DRIVE CHAIN

1. Bend down lock tab ①.
2. Put the transmission in gear and apply parking brake.
3. Loosen:
 - Nut (Drive sprocket) ②
4. Remove:
 - Drive sprocket
 - Drive chain

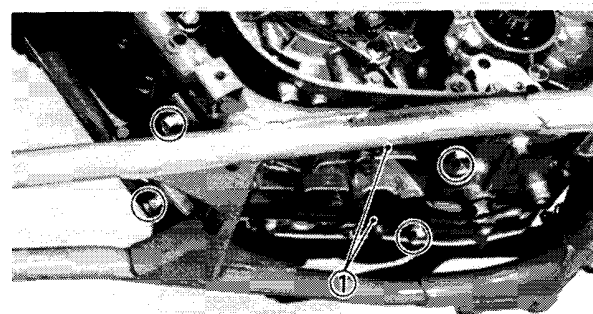

TENSION ROD

1. Remove:
 - Tension rods ①

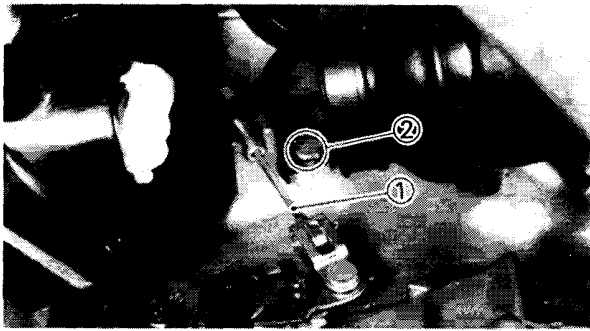

CABLES

1. Disconnect:
 - Spark plug lead
2. Remove:
 - Clutch cable ①
First disconnect the handlebar lever side, and then crankcase side.
 - Cable holder ②
3. Remove:
 - Cable guide ①

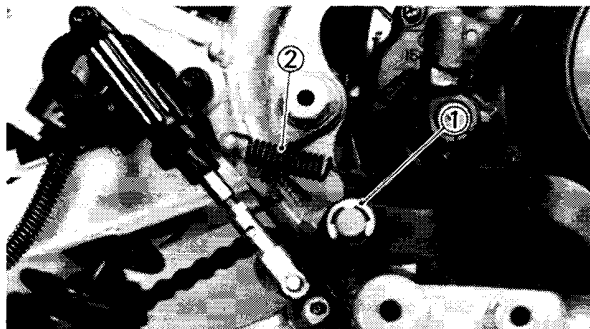
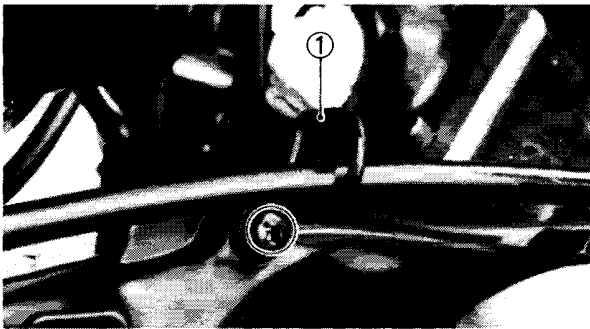

ENGINE REMOVAL

1. Remove:
 - Circlip ①
 - Spring ②
2. Remove:
 - Bolts ① (Rear brake master cylinder)
 - Rear brake pedal

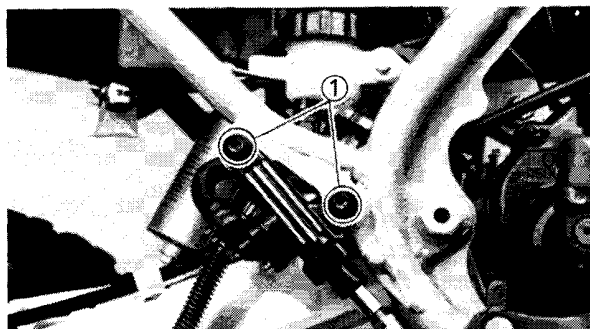

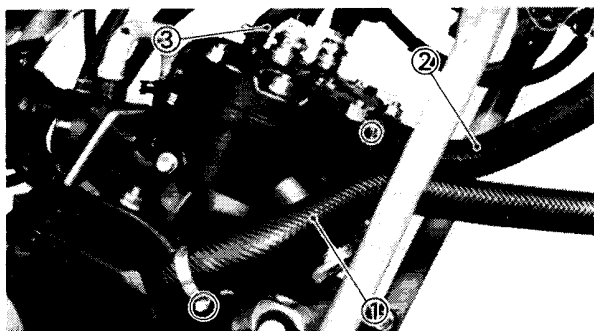

3. Disconnect:
- Inlet hose ①
 - Outlet hose ②
 - Bypass hose ③

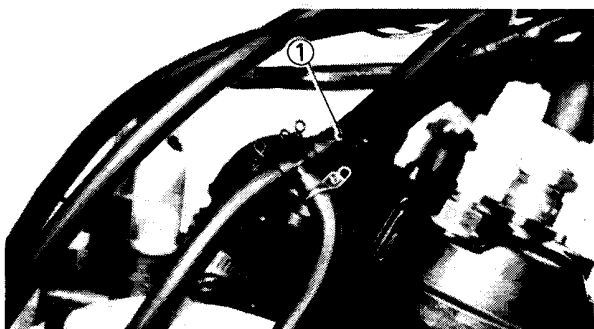

4. Disconnect:
- Breather hose ①

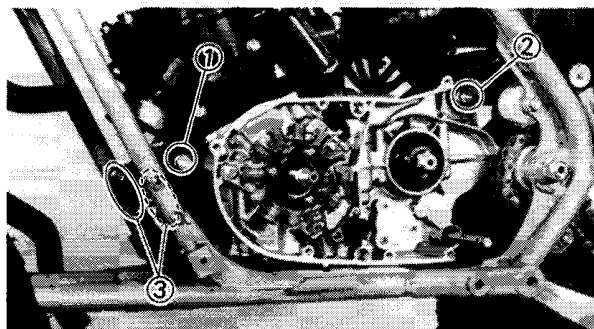

5. Remove:
- Bolt (Engine mounting-Front) ①
 - Bolt (Engine mounting-Rear) ②
 - Bolts (Engine stay-Front) ③

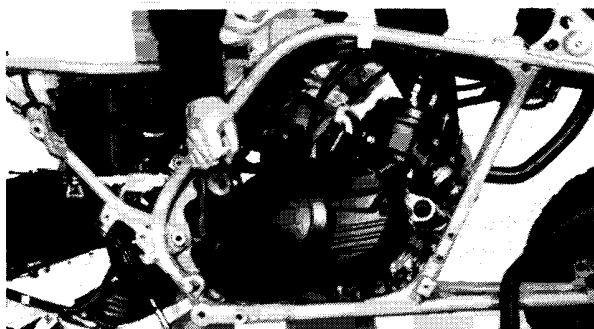

6. Remove:
- Engine
To the right

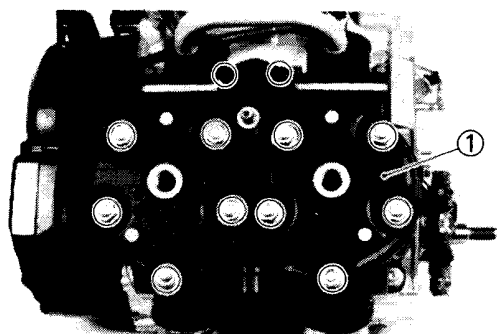

DISASSEMBLY CYLINDER HEAD

1. Remove:
 - Cylinder head ①
 - Gasket (Cylinder head)

NOTE:

1. Before loosening the cylinder head, loosen the spark plugs.
2. The cylinder head bolts should be loosened starting from No.10.
Loosen them 1/2 turn each time, and remove.

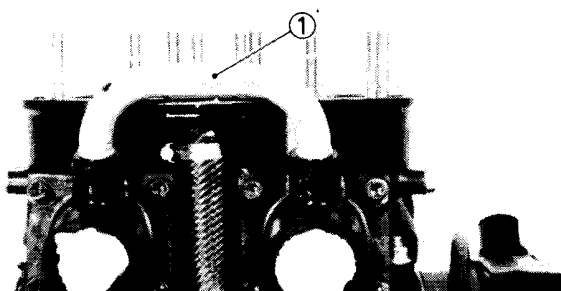

REED VALVE ASSEMBLY

1. Remove:
 - Pipe ①

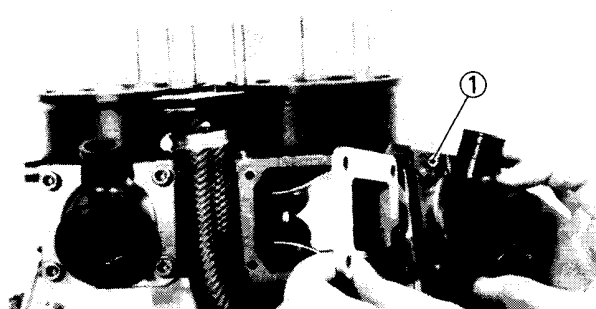

2. Remove:
 - Carburetor joint ①
 - Reed valve assembly

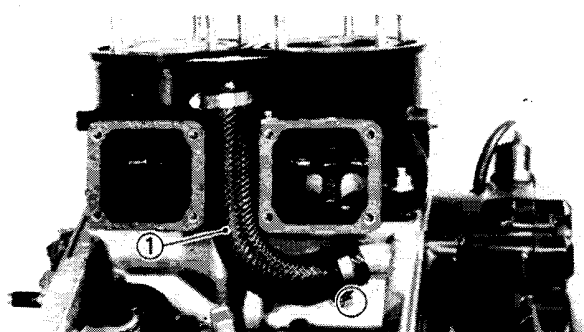

RADIATOR HOSE

1. Remove:
 - Radiator hose ①

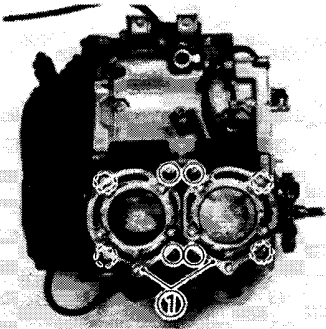
**CYLINDER**

1. Remove:
 - Cylinders ①
 - Cylinder gaskets
 - Dowel pins
2. Place the cylinder in an inverted position, and drain the coolant.

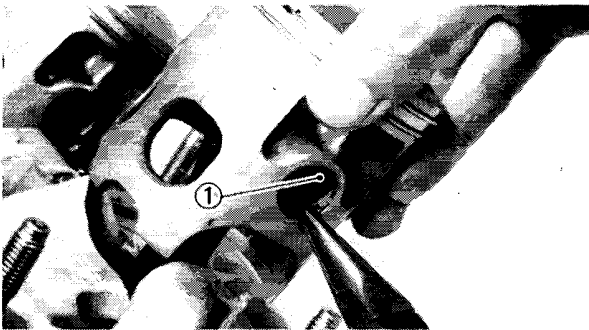
**PISTON PIN AND PISTON**

1. Remove:
 - Piston pin clip ①

NOTE:

Before removing the piston pin clip, cover the crankcase with a clean rag so you will not accidentally drop the clip into the crankcase.

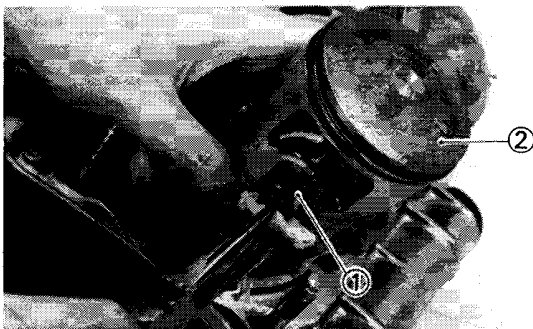

2. Remove:
 - Piston pin ①
 - Piston ②
 - Bearing (Small end)

NOTE:

Before removing the piston pin, deburr the clip groove and pin hole area. If the piston pin groove is deburred and piston pin is still difficult to remove, use Piston Pin Puller (YU-01304).

CAUTION:

Do not use a hammer to drive the piston pin out.

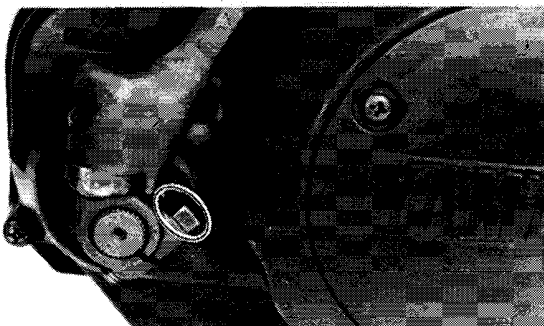
**KICK CRANK**

1. Remove:
 - Kick crank

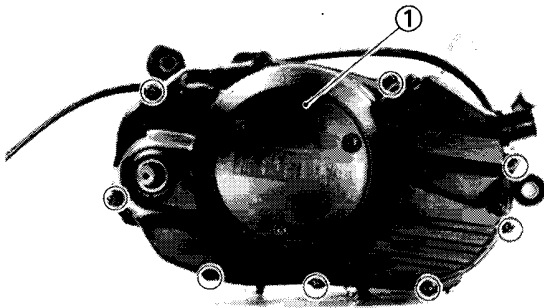
**CRANKCASE COVER (RIGHT)**

1. Remove:

- Crankcase cover (Right) ①
- Dowel pin

NOTE:

The crankcase cover can be removed without removing the water pump.

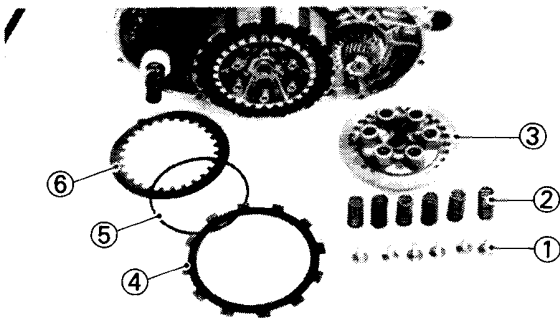
**CLUTCH AND PRIMARY DRIVE GEAR**

1. Remove:

- Clutch spring holding screws ①
- Clutch springs ②
- Pressure plate ③
- Friction plates ④
- Cushion rings ⑤
- Clutch plates ⑥

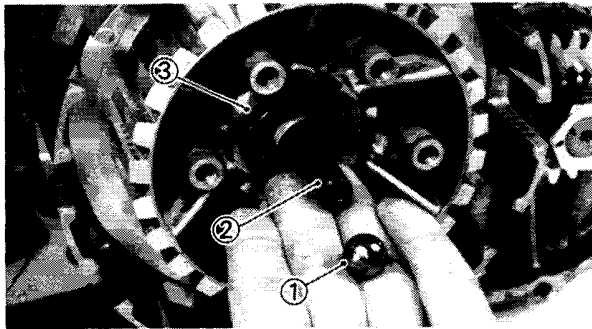

2. Remove:

- Ball ①
- Push rod #2 ②

3. Straighten:

- Lock washer tab ③

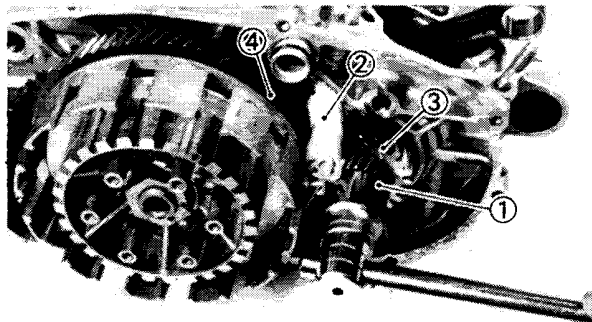

4. Loosen:

- Nut ① (Primary drive gear)
Place a folded rag ② between the teeth of the drive gear ③ and driven gear ④ to lock them.

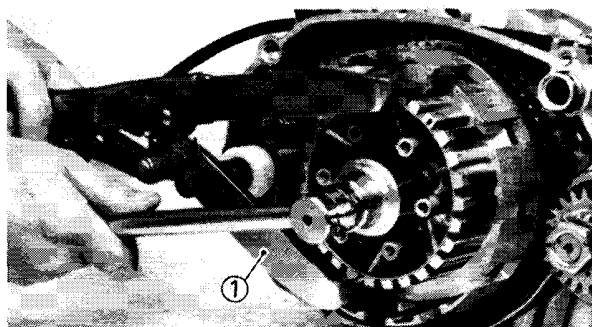

5. Loosen:

- Nut (Clutch boss)
Use the Universal Clutch Holder ① (YM-91042).

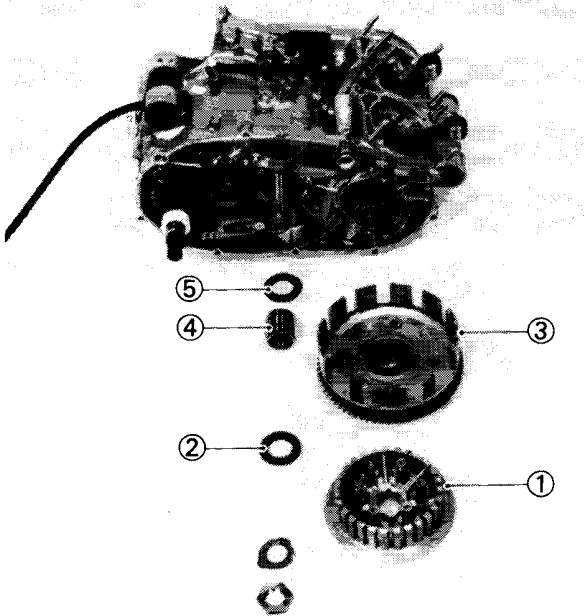

6. Remove:
- Clutch boss ①
 - Thrust plate ②
 - Clutch housing ③
 - Spacer ④
 - Thrust plate ⑤

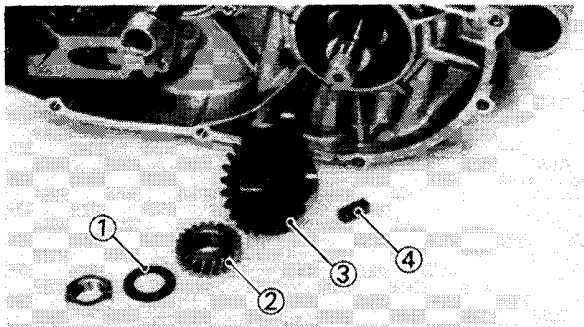

7. Remove:
- Conical spring washer ①
 - Water pump drive gear ②
 - Primary drive gear ③
 - Key ④

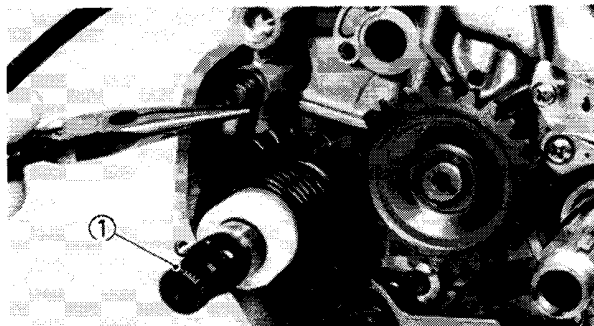

KICK AXLE

1. Unhook the kick spring from its position.
2. Remove:
 - Kick axle assembly ①

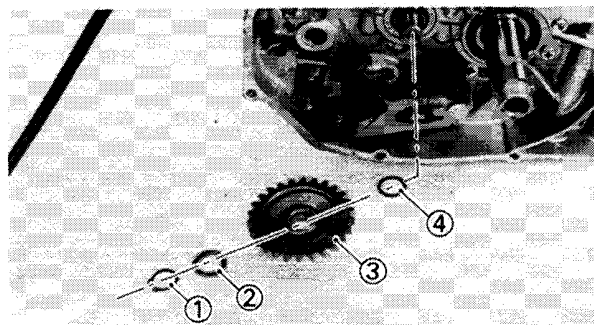

3. Remove:
- Circlip ①
 - Washer ②
 - Kick idle gear ③
 - Plain washer ④

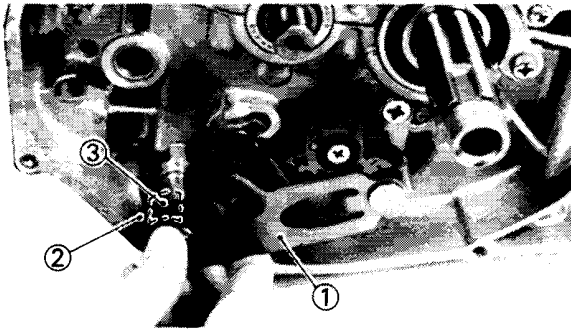
**CHANGE SHAFT**

1. Remove:
 - Change lever ①
 - Spring ②
 - Collar ③

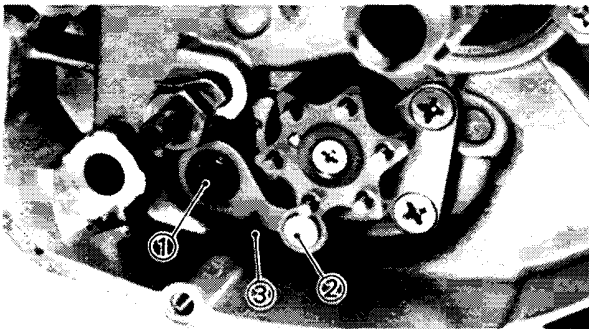

2. Unhook the torsion spring from its position.
3. Remove:
 - Securing bolt ①
 - Stopper lever ②
 - Spring ③

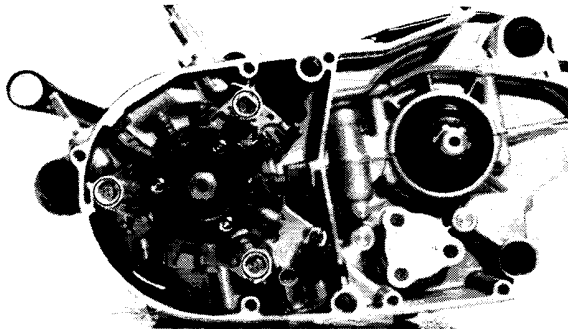
**STATOR ASSEMBLY**

1. Remove:
 - Stator assembly

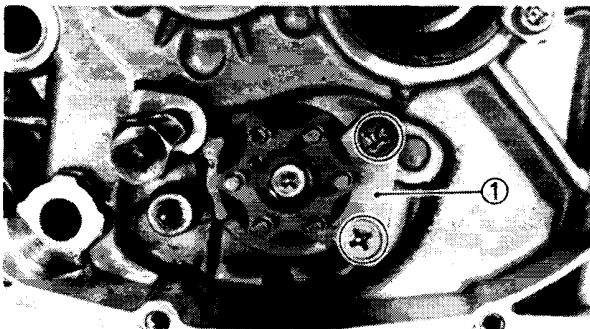
**CAM STOPPER PLATE**

1. Remove:
 - Cam stopper plate ①

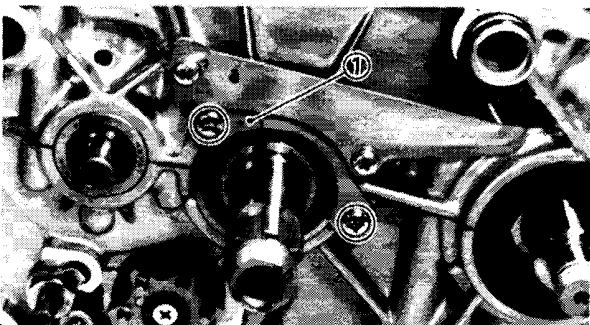
**BEARING STOPPER PLATE**

1. Remove:
 - Bearing stopper plate ①

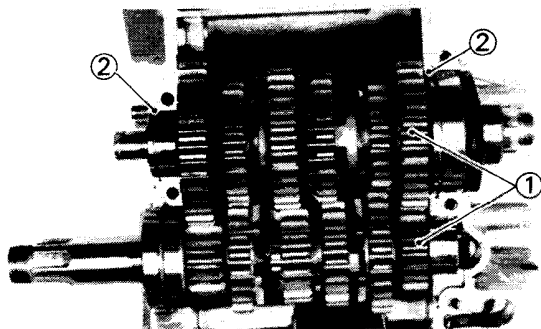
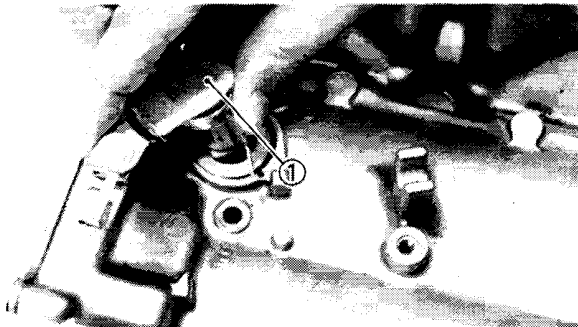
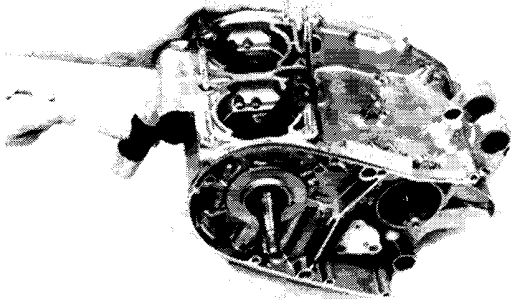
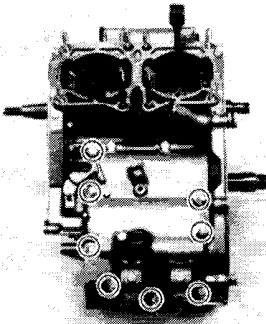
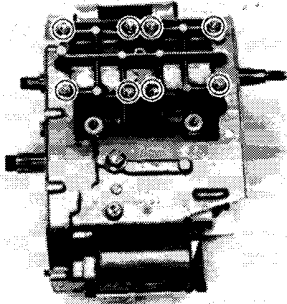
**CRANKCASE**

1. Remove:

- Nuts (Crankcase)
- Bolts (Crankcase)

NOTE:

Loosen each bolt and nut 1/4 turn, and remove them after all are loosened.

2. Remove:

- Upper crankcase
- Dowel pins

NOTE:

Split crankcase by lightly striking the front and rear parts of the upper crankcase.

PUSH LEVER

1. Remove:

- Push lever ①

TRANSMISSION

1. Remove:

- Transmission assembly ①
- Circlips ②

NOTE:

Remove the transmission by lightly striking it with a soft-faced hammer at case mating surface.

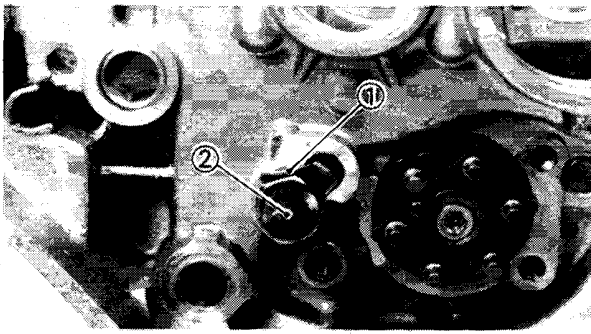

SHIFTER

1. Straighten:
 - Lock washer tab ①
2. Remove:
 - Bolt ②

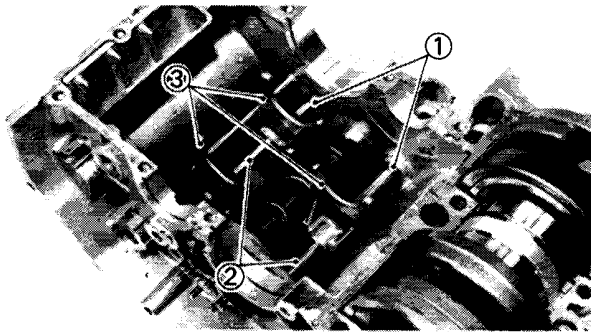

3. Remove:
 - Circlip ①
 - Guide bars ②
 - Shift forks ③

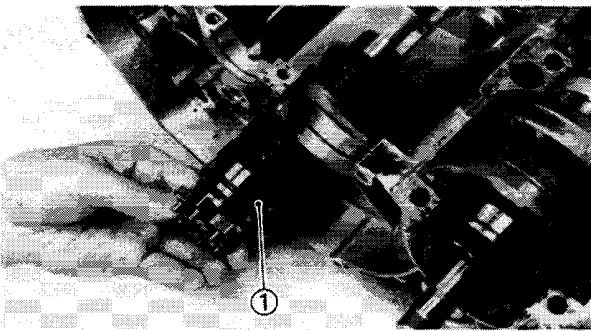

4. Remove:
 - Shift cam ①

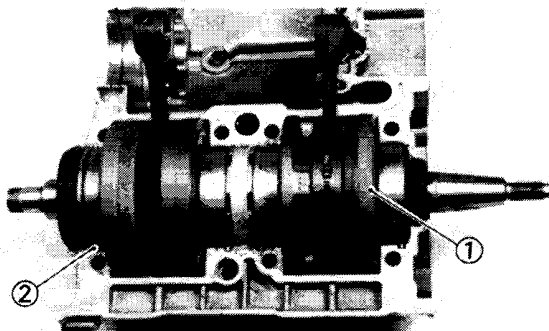

CRANKSHAFT

1. Remove:
 - Crankshaft ①
 - Circlip ②

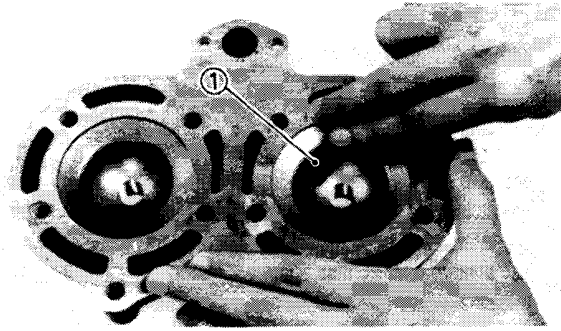

**INSPECTION AND REPAIR
CYLINDER HEAD**

1. Remove:
 - Carbon deposits
Use a scraper ①.

NOTE:

Take care to avoid damaging the spark plug threads. Do not use a sharp instrument. Avoid scratching the aluminum.

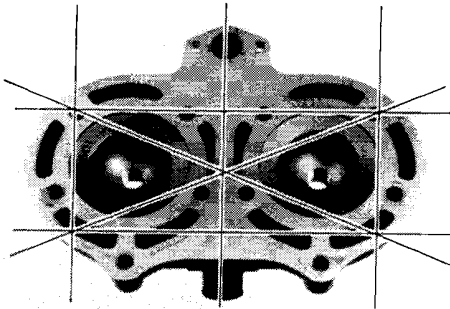

2. Inspect:
 - Cylinder head water jacket crust of minerals/Rust → Remove.
 - Cylinder head warpage out of specification → Re-surface.

Warpage measurement and re-surface-ment steps:

- Attach a straight edge and a thickness gauge on the cylinder head.
- Measure the warpage limit.



Warpage Limit:
0.03 mm (0.0012 in)

- If the warpage is out of specification, resurface the cylinder head.
- Place a 400 ~ 600 grit wet sandpaper on the surface plate, and re-surface the head using a figure-eight sanding pattern.

NOTE:

Rotate the head several times to avoid removing too much material from on side.

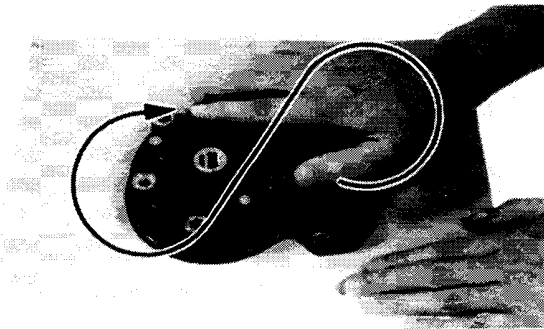

CYLINDER

1. Remove:
 - Carbon deposits
Use a rounded scraper.
2. Inspect:
 - Cylinder water jacket
Crust of minerals/Rust → Remove.
 - Cylinder wall
Wear/Scratches → Rebore or replace.

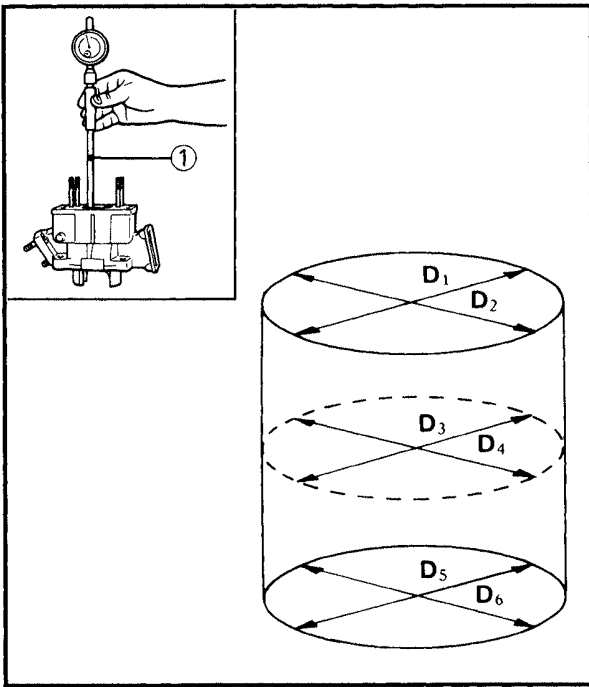

3. Measure:
- Cylinder bore "C"
- Out of specification → Rebore.
Use a Cylinder Bore Gauge ①.

	Standard	Wear limit
Cylinder bore "C"	64.00 mm (2.520 in)	64.10 mm (2.524 in)
Taper "T"	—	0.05 mm (0.002 in)
Out of round "R"	—	0.01 mm (0.0004 in)

C = Maximum D
T = (Maximum D₁ or D₂) – (Minimum D₅ or D₆)
R = (Maximum D₁, D₃ or D₅) – (Minimum D₂, D₄ or D₆)

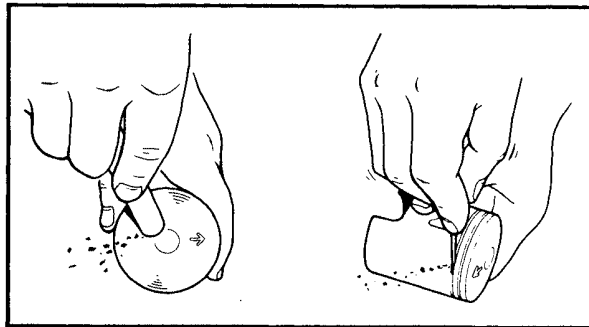

PISTON, PISTON RING AND PISTON PIN

Piston

1. Remove:
- Carbon deposits
- From the piston crown and ring grooves.
2. Inspect:
- Piston wall
- Wear/Scratches/Damage → Replace.

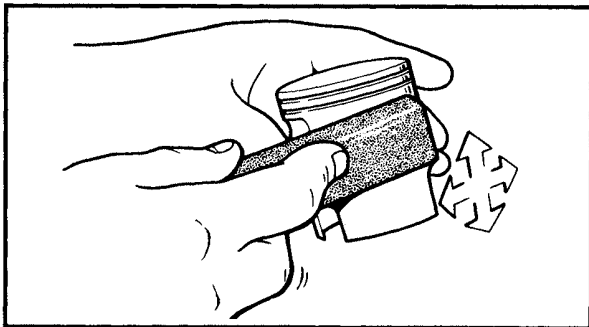

3. Remove:
- Score marks and lacquer deposits
- From the sides of piston.
Use a 600 ~ 800 grit wet sandpaper.

NOTE: _____
 Sand in a crisscross pattern. Do not sand excessively.

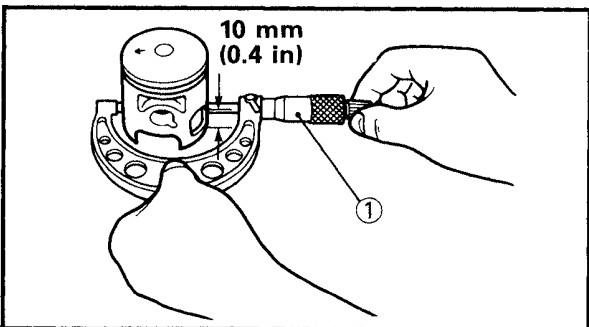

4. Measure:
- Piston outside diameter "P"
- Out of specification → Replace.
Use a Micrometer ①.

NOTE: _____
 Measurement should be made at a point 10 mm (0.4 in) above the bottom edge of the piston.



Piston Outside Diameter "P"	
Standard	63.94 ~ 64.00 mm (2.517 ~ 2.521 in)
Oversize 1	64.25 mm (2.53 in)
Oversize 2	64.50 mm (2.54 in)

5. Measure:

- Piston Clearance
Out of specification → Rebore cylinder or replace piston.

Piston Clearance = C - P:	
0.060 ~ 0.065 mm (0.0024 ~ 0.0026 in)	
C: Cylinder Bore P: Piston Outside Diameter	

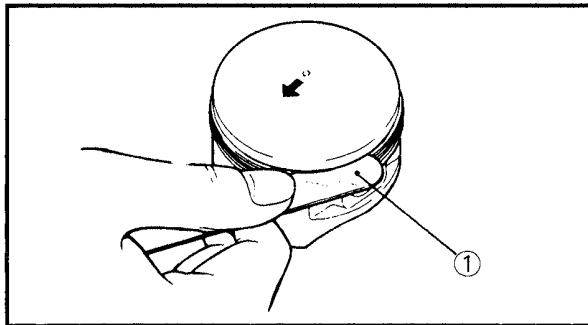

Piston Ring

1. Measure:

- Side clearance
Out of specification → Replace piston and/or rings.
Use the Feeler Gauge ①.

	Side clearance	
	Standard	Limit
Top Ring	0.02 ~ 0.06 mm (0.0008 ~ 0.0024 in)	0.12 mm (0.0047 in)
2nd Ring	0.02 ~ 0.06 mm (0.0008 ~ 0.0024 in)	0.12 mm (0.0047 in)

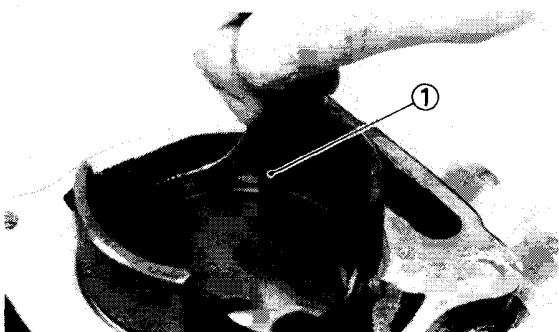

2. Position:

- Piston ring
Into the cylinder.
Push the ring with the piston crown.

3. Measure:

- End gap
Out of specification → Replace rings as a set.
Use a Feeler Gauge ①.

	End Gap	
	Standard	Limit
Top ring	0.30 ~ 0.45 mm (0.012 ~ 0.018 in)	0.70 mm (0.028 in)
2nd ring	0.30 ~ 0.45 mm (0.012 ~ 0.018 in)	0.70 mm (0.028 in)

Piston Ring Oversize

- Top and 2nd piston ring
- Oversize top and 2nd ring sizes are stamped on top of ring.

Oversize 1	"25"	0.25 mm (0.0098 in)
Oversize 2	"50"	0.50 mm (0.0197 in)

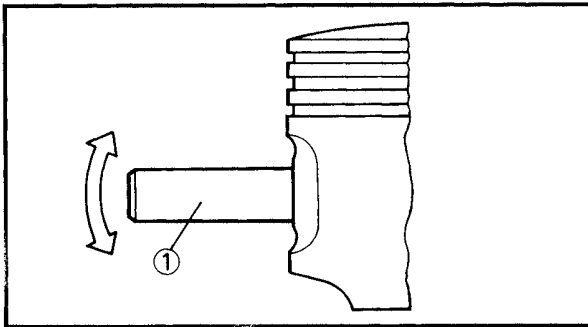
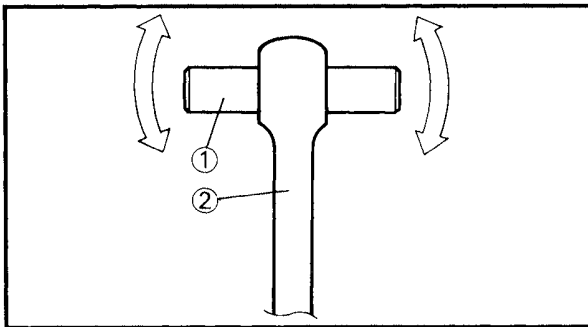

Piston Pin

- Lubricate:
 - Piston pin (lightly)
- Install:
 - Piston pin ①
 - Into the small end of connecting rod ②.
- Check:
 - Free play
 - There should be no noticeable for the play.
 - Free play exists → Inspect the connecting rod for wear/Replace the pin and/or connecting rod as required.
- Install:
 - Piston Pin ①
 - Into the piston.
- Check:
 - Free play (when the piston pin is in place in the piston)
 - There should be no noticeable for the play.
 - Free play exists → Replace piston pin and/or piston.
- Inspect:
 - Piston pin and bearing
 - Signs of heat discoloration → Replace.

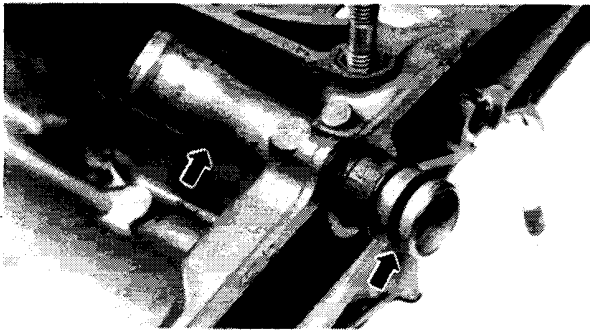

JOINT PIPE

1. Inspect:
 - Joint pipe
Crack → Replace.
 - O-ring
Damage → Replace.

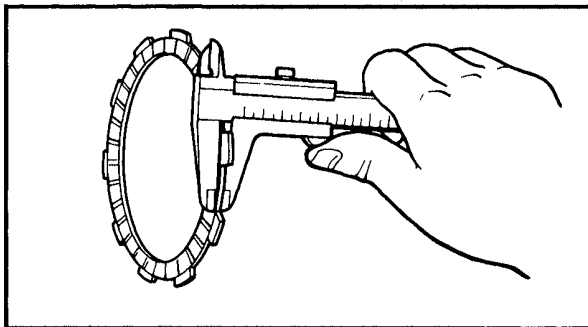

CLUTCH

Friction Plates

1. Inspect:
 - Friction plate
Damage/Wear → Replace friction plate as a set.
2. Measure:
 - Friction plate thickness
Out of specification → Replace friction plate as a set.
Measure at all four point.

	Friction Plate Thickness
Wear Limit	2.7 mm (0.106 in)

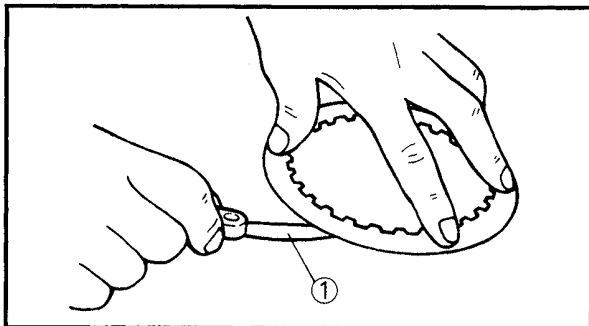

Clutch Plates

1. Measure:
 - Clutch plate warpage
Out of specification → Replace clutch plate as a set.
Use a surface plate and feeler gauge ①.

	Warp Limit: 0.05 mm (0.002 in)
---	---

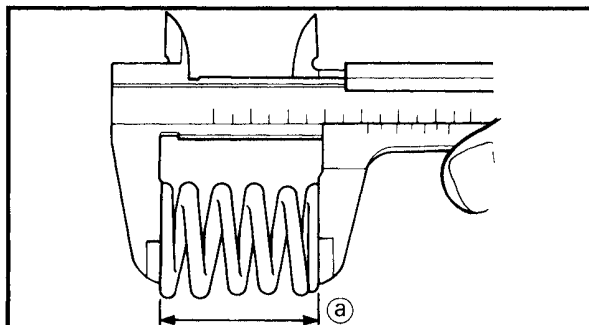

Clutch Spring

1. Measure:
 - Clutch spring free length ②
Out of specification → Replace spring as a set.

	Clutch Spring Minimum Length: 34.4 mm (1.35 in)
---	--

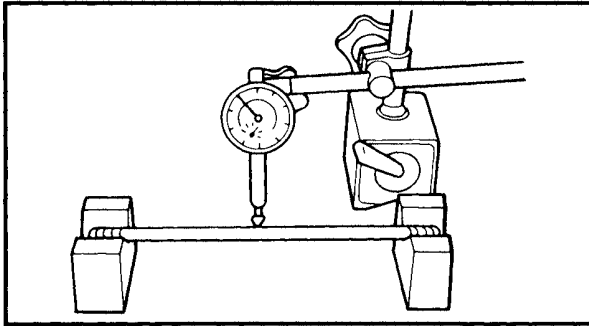

Push Rod

1. Measure:

- Push rod runout (Long rod)
Out of specification → Replace.
Use the V-Blocks and Dial Gauge.



Bending Limit:

0.2 mm (0.008 in)

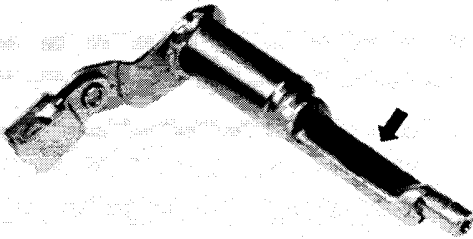

Push Lever

1. Inspect:

- Push lever
Wear/Damage → Repair using 300 ~ 400 grit sand paper or replace.

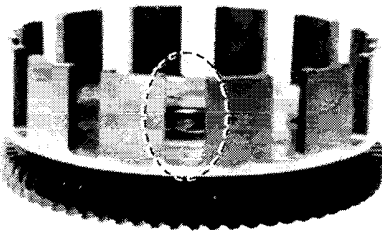

Clutch Housing

1. Inspect:

- Dogs on the clutch housing
Cracks/Wear/Damage → Deburr or replace.
- Clutch housing bearing
Chafing/Wear/Damage → Replace.

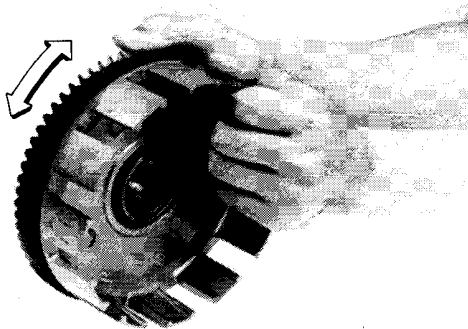

2. Check:

- Circumferential play
Free play exists → Replace.

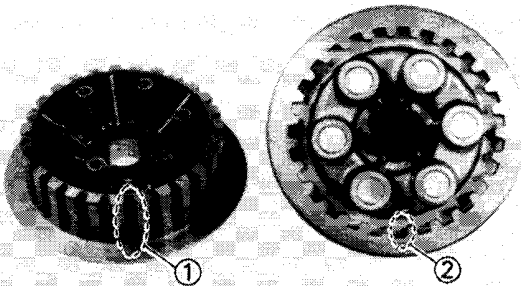

Clutch Boss and Pressure Plate

1. Inspect:

- Clutch boss splines ①
- Pressure plate ②
Scoring/Wear/Damage → Replace clutch boss and/or pressure plate.

NOTE:

Scoring on the clutch boss splines will cause erratic operation.

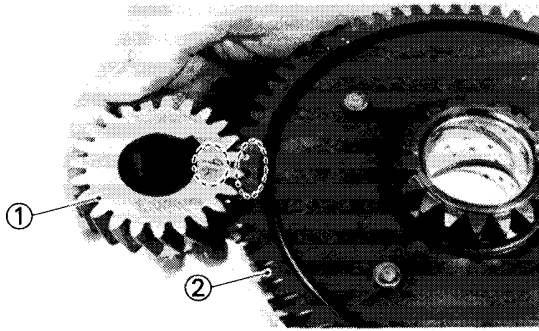

PRIMARY DRIVE GEAR

1. Inspect:
 - Drive gear and driven gear
Pitting/Wear/Damage → Replace.
2. It is always advisable to pay strict attention to the lash numbers (mark) during replacement. Marks are scribed on the side of each gear. Match these marks.

- ① Drive gear
- ② Driven gear

Primary drive gear	Primary driven gear	Lash tolerance A + B
Lash number A	Lash number B	
90 ~ 98	57 ~ 65	154 ~ 156

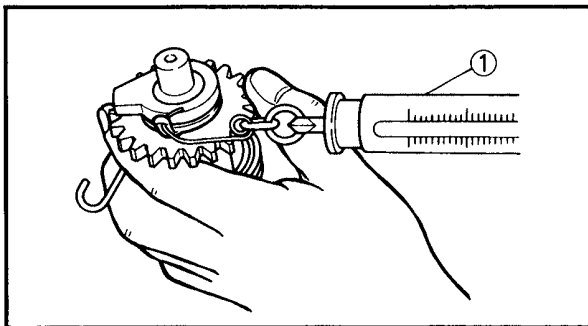

KICK STARTER

1. Inspect:
 - Kick axle
Damage/Wear → Replace.
2. Measure:
 - Kick spring tension
Out of specification → Replace.
Use a spring balance ①.

	Standard Tension:
	0.8 ~ 1.3 kg (1.8 ~ 2.9 lb)

CAUTION:

Do not try to bend the clip.

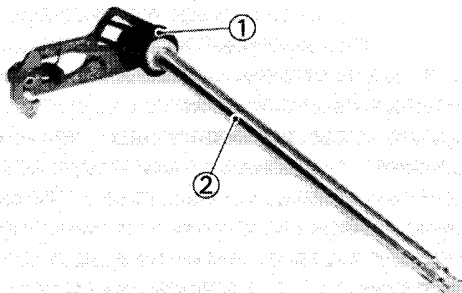

SHIFTER

1. Inspect:
 - Shift return spring ①
Damage → Replace.
 - Change shaft ②
Damage/Bends/Wear → Replace.

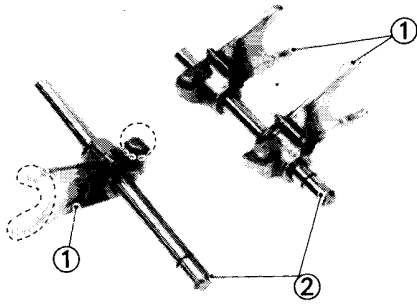

TRANSMISSION

Shift Fork

1. Inspect:

- Shift forks ① (Gear and shift cam contact surfaces)
Wear/Chafing/Bends/Damage → Replace.
- Guide bars ②
Bends/Wear → Replace.

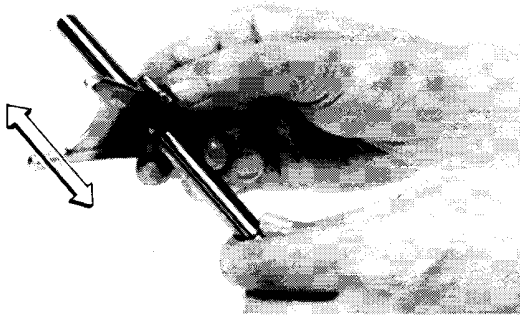

2. Check:

- Shift fork movement
On its guide bar.
Unsmooth operation → Replace shift fork and/or guide bar.

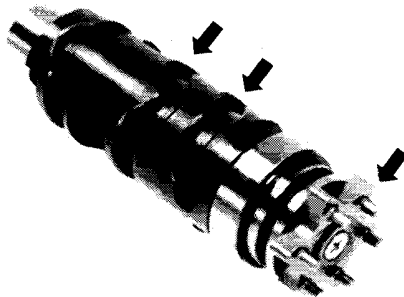

Shift Cam

1. Inspect:

- Shift cam grooves
Wear/Damage/Scratches → Replace.
- Shift cam segment
Damage/Wear → Replace.

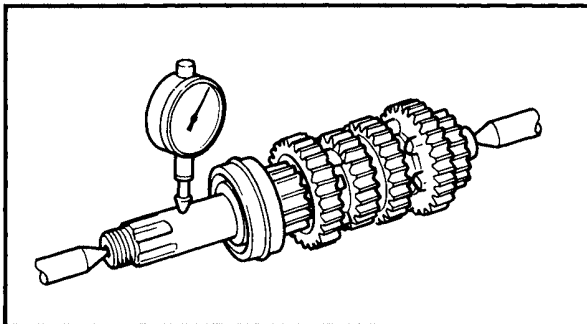

Main and Drive Axles

1. Measure:

- Axle runout
Out of specification → Replace.
Use centering device and Dial Gauge.



Runout Limit:
0.08 mm (0.0031 in)

Gears

1. Inspect:

- Gears
- Mating dogs
Cracks/Damage/Wear → Replace.

2. Check:

- Gear movement
Unsmooth operation → Replace.

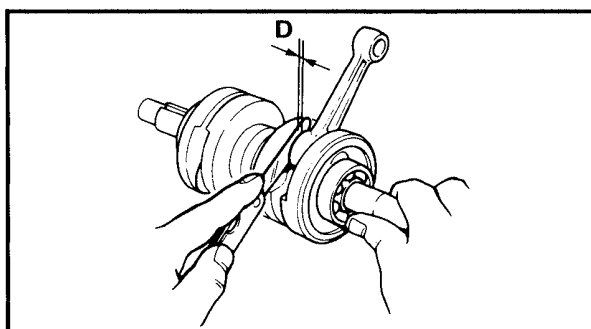
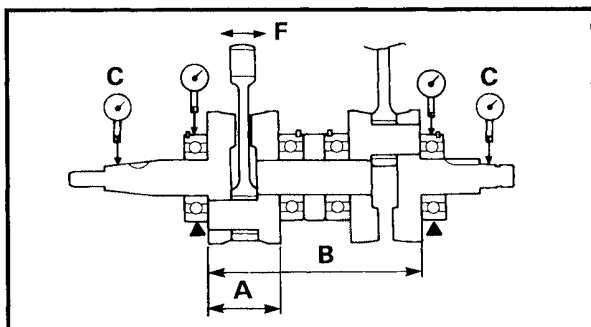
**CRANKSHAFT****Crankshaft Inspection****1. Measure:**

- Assembly width "A" and "B"
Use the V-blocks.
Out of specification → Replace.

**Assembly Width "A":**

53.95 ~ 54.00 mm
(2.124 ~ 2.126 in)

Assembly Width "B":

155.90 ~ 156.05 mm
(6.138 ~ 6.144 in)

- Big end side clearance "D"

Use a Feeler Gauge.

Out of specification → Disassemble the crankshaft and replace worn parts, then reassemble the crankshaft.

**Big End Side Clearance Limit "D":**

0.25 ~ 0.75 mm (0.0098 ~ 0.0295 in)

- Runout "C"

Use the V-blocks and Dial Gauge.

Out of specification → Correct any misalignment.

**Runout Limit "C":**

0.05 mm (0.002 in)

- Small end free play "F"

Use the V-blocks and Dial Gauge.

Out of specification → Disassemble the crankshaft, and replace the defective parts, then reassemble the crankshaft.

**Small End Free Play "F":**

Standard: 0.36 ~ 0.98 mm
(0.0142 ~ 0.0386 in)
Limit: 2.0 mm (0.08 in)

2. Inspect:

- Crankshaft bearing surfaces
Wear/Scratches/Rust spots → Replace.

NOTE:

Lubricate the bearing immediately after examining then to prevent rust.



BEARINGS AND OIL SEALS

1. Inspect:

- Bearings
Pitting/Damage→Replace.
- Oil seal lips
Damage/Wear→Replace.

CIRCLIPS AND WASHERS

1. Inspect:

- Circlips
- Washers
Damage/Looseness/Bends→Replace.

CRANKCASE

1. Thoroughly wash the case halves in mild solvent.
2. Clean all the gasket mating surfaces and crankcase mating surfaces thoroughly.
3. Inspect:
 - Crankcase
Cracks/Damage→Replace.
 - Oil delivery passages
Clog→Blow out with compressed air.